



Pulsar Weather Station™ User Manual



Pulsar Weather Station™

User Manual

Version 1.18

Serial Number: _____

Date Purchased: _____

All specifications subject to change without notice.

Printed in U. S. A.

© Copyright 2025 Columbia Weather Systems, Inc. All Rights Reserved.

Proprietary Notice: Pulsar Weather Station, Orion Weather Station, Capricorn 2000 Weather Station, Capricorn 2000MP Weather Station, Capricorn 2000EX Weather Station, Magellan MX Weather Station, Magellan Weather Station, Vela Weather Station and Weather MicroServer are trademarks of Columbia Weather Systems, Inc. The information and drawings contained herein are the sole property of Columbia Weather Systems, Inc. Use of this publication is reserved exclusively for customers of Columbia Weather Systems, Inc. and their personnel. Reproduction of this material is forbidden without the express written consent of Columbia Weather Systems, Inc.

Welcome!

Congratulations on your purchase of a Pulsar Weather Station.

Please read this manual completely prior to installation.

Important Notice: Shipping Damage

BEFORE YOU READ ANY FURTHER, please inspect all system components for obvious shipping damage. The Pulsar is a high precision instrument and can be damaged by rough handling. Your unit was packaged to minimize the possibility of damage in transit. Please save the shipping container for any future shipment of your Pulsar sensor.

In the event your order arrives in damaged condition, it is important that the following steps be taken immediately. The title transfers automatically to you, the customer, once the material is entrusted to the transport company.

NOTE: DO NOT RETURN THE INSTRUMENT TO COLUMBIA WEATHER SYSTEMS until the following steps are completed. Failure to follow this request will jeopardize your claim.

1. Open the container and inspect the contents. Do not throw away the container or any damaged parts. Try to keep items in the same condition as originally received.
2. Notify the transport company immediately.
3. Request the transport company's representative inspect the shipment personally.
4. After inspection, request a Return Materials Authorization (RMA) from Columbia Weather Systems by calling (503) 629-0887.
5. Return approved items to us at the following address:

Columbia Weather Systems, Inc.

5285 NE Elam Young Parkway, Suite C100

Hillsboro, OR 97124

6. After a repair evaluation, an estimate of the cost of repair will be sent to you.

ESD Protection

Electrostatic Discharge (ESD) can cause immediate or latent damage to electronic circuits. The Pulsar is adequately protected against ESD for its intended use. However, it is possible to damage the product by delivering electrostatic discharges when touching, removing, or inserting any objects inside the equipment housing.

To avoid delivering high static voltages to yourself:

1. Handle ESD sensitive components on a properly grounded and protected ESD workbench. When this is not possible, ground yourself with a wrist strap and a resistive connection cord to the equipment chassis before touching the boards. When neither of the above is possible, at least touch a conductive part of the equipment chassis with your other hand before touching the boards.
2. Always hold the boards by the edges and avoid touching the component contacts.

Table of Contents

WELCOME!	3
IMPORTANT NOTICE: SHIPPING DAMAGE	5
ESD PROTECTION	6
SECTION 1: INTRODUCTION	11
THE PULSAR WEATHER STATION	11
SPECIFICATIONS	12
<i>Operating Conditions</i>	12
<i>Wind Speed</i>	12
<i>Wind Direction</i>	12
<i>Relative Humidity</i>	12
<i>Temperature</i>	12
<i>Barometric Pressure</i>	13
<i>Precipitation</i>	13
<i>Compass</i>	13
<i>Solar Radiation</i>	13
<i>Input Voltage</i>	14
<i>Heating</i>	14
<i>Heating Power Source</i>	14
<i>Power Consumption (without heating)</i>	15
<i>Power Consumption (@ 24VDC - with heating)</i>	15
<i>Dimensions & Weights</i>	16
<i>Sensor Housing</i>	16
<i>Electrical Conformity</i>	17
PULSAR 10 SPECIFICATIONS	18
<i>Operating Conditions</i>	18
<i>Wind Speed</i>	18
<i>Wind Direction</i>	18
<i>Relative Humidity</i>	18
<i>Temperature</i>	18
<i>Barometric Pressure</i>	18
<i>Precipitation</i>	19
<i>Compass</i>	19
<i>Solar Radiation</i>	19
<i>UV Index</i>	19
<i>Dimensions & Weight</i>	19
<i>Sensor Housing</i>	19
PRINCIPLES OF MEASUREMENTS	20
<i>Temperature & Relative Humidity</i>	20
<i>Wind Speed & Direction</i>	20
<i>Barometric Pressure</i>	20
<i>Precipitation</i>	20

<i>Solar Radiation</i>	21
<i>(501 Model)</i>	21
<i>(700 & 800 Model)</i>	21
<i>Lightning Detection</i>	21
<i>Compass</i>	21
<i>Ventilation Fan</i>	21
<i>GPS (Global Positioning System) Pulsar 10 Only</i>	22

SECTION 2: PHYSICAL DESCRIPTION.....23

PULSAR SENSOR TRANSMITTER	23
<i>Pulsar 10</i>	25
<i>Pulsar 100</i>	27
<i>Pulsar 200</i>	28
<i>Pulsar 400</i>	29
<i>Pulsar 500</i>	30
<i>Pulsar 501</i>	31
<i>Pulsar 600</i>	32
<i>Pulsar 601</i>	33
<i>Pulsar 700</i>	34
<i>Pulsar 800</i>	35
INTERFACE MODULE	36
SURGE/LIGHTNING PROTECTOR	37
WEATHER MICROSERVER (REQUIRED)	38
WEATHERMASTER™ SOFTWARE (OPTIONAL)	39
WEATHER DISPLAY CONSOLE (OPTIONAL)	40

SECTION 3: SYSTEM CONFIGURATIONS.....41

<i>Cabled System COM2 Connection</i>	41
<i>System with Weatherproof Enclosure</i>	43
<i>Wireless System with Weatherproof Enclosure:</i>	44
<i>4-20mA Industrial Interface</i>	46

SECTION 4: INSTALLATION51

INSTALLATION OVERVIEW	51
UNPACKING THE UNIT	51
<i>Installing the Pulsar Sensor Transmitter</i>	53
<i>Site Selection:</i>	53
<i>Installing the Mast</i>	53
<i>Location</i>	53
<i>Mounting Method</i>	53
<i>Routing Cable</i>	54
<i>Sensor Mounting Hardware</i>	55
<i>Mounting Adapter</i>	56
<i>Installation Procedure</i>	56
<i>North Alignment – Integrated Electronic Compass</i>	57
<i>Manual North Alignment (Optional Procedure)</i>	57

<i>Installing the Surge Arrestor</i>	59
<i>Connecting the Sensor Transmitter to the Interface Module</i>	60
OPTIONAL SENSOR MOUNTING HARDWARE.....	61
<i>Tripod and Tiedown Kit</i>	61
<i>Specifications</i>	62
<i>Sensor Mast</i>	63
<i>Roof Mounting</i>	63
<i>Wall Mounting</i>	64
PULSAR 10 INSTALLATION.....	66
SECTION 5: CALIBRATION & MAINTENANCE	67
FACTORY CALIBRATION AND REPAIR SERVICE.....	67
CLEANING.....	67
SECTION 6: TROUBLESHOOTING	69
<i>Loss of communication with Pulsar sensor transmitter</i> :.....	70
SECTION 7: USER SUPPORT INFORMATION	71
LIMITED WARRANTY.....	71
EXCLUSIONS.....	71
RETURN FOR REPAIR PROCEDURE.....	72
REFERENCE	74
GLOSSARY.....	74
<i>Aspirating Radiation Shield</i>	74
<i>Barometric Pressure</i>	74
<i>Celsius Temperature Scale</i>	74
<i>Dew Point</i>	74
<i>Density Altitude</i>	74
<i>Fahrenheit Temperature Scale</i>	74
<i>Global Radiation</i>	75
<i>Heat Index</i>	75
<i>Pyranometer</i>	75
<i>Relative Humidity</i>	75
<i>Sea Level Pressure</i>	75
<i>Solar Radiation</i>	76
<i>Wind Chill</i>	76
UNIT CONVERSION.....	76
<i>Speed</i>	76
<i>Temperature</i>	76
<i>Distance</i>	76
<i>Pressure</i>	76
TABLES AND FORMULAS.....	77
<i>Wind Chill Chart</i>	77
<i>Wind Chill Equation</i>	78
<i>Heat Index</i>	79

Dew Point 80

SECTION 1: INTRODUCTION

The Pulsar Weather Station

The Pulsar is a highly accurate weather station designed around an all-in-one sensor module and the Weather MicroServer.

The Weather MicroServer is available for Ethernet connectivity, Modbus/TCP, Modbus RTU, SNMP V2/V3 interface, DNP3 Ethernet/Serial, BACnet, CWS Weather Server, Weather Underground, Anything Weather and CWOP interface, XML weather data, and FTP.

Please see the MicroServer user manual for more information.

Specifications

Operating Conditions

Temperature Operation: -58 to +140°F (-50 to +60°C)

Relative humidity: 0 to 100%

Wind Speed

Range: 0 to 167 mph (0 to 75 m/s) (WS 601: 0 to 67 mph (0 to 30 m/s))

Accuracy: ± 0.67 mph (± 0.3 m/s)

or $\pm 3\%$ 0 to 78 mph (0 to 35 m/s) $\pm 5\%$ >78mph

Resolution: 0.2 mph (0.1 m/s)

Units Available: knots, mph, km/hr, m/s

Wind Direction

Measurement Range: 0 to 359.0°

Accuracy: $< 3^\circ$ (> 1 m/s)

Resolution: 0.1°

Response threshold: 0.01 mph (0.3 m/s)

Units Available: degrees

Relative Humidity

Range: 0 to 100%

Accuracy: $\pm 2\%$ RH

Resolution: 0.1% RH

Units Available: %RH

Temperature

Range: -58 to 140°F (-50 to +60°C)

Accuracy: $\pm 0.36^\circ\text{F}$ (-4 to 122°F) otherwise $\pm 0.9^\circ\text{F}$ ($> -22^\circ\text{F}$)

$\pm 0.2^\circ\text{C}$ (-20°C to +50°C), otherwise $\pm 0.5^\circ\text{C}$ ($> -30^\circ\text{C}$)

Resolution: 0.18°F (-4 to 122°F) otherwise 0.36°F

0.1°C (-20°C...+50°C), otherwise 0.2°C

Units Available: °F, °C

Barometric Pressure

Range: 8.85 to 35.4 inHg (300 to 1200 hPa)

Accuracy: ± 0.015 inHg (0.5 hPa) (32 to 104°F)

Resolution: 0.003 inHg (0.1 hPa)

Units Available: kPa, hPa, mbar, inHg

Precipitation

Doppler Radar

Measurement Range (drop size): (0.01 to 0.2 in) (0.3 to 5 mm)

Resolution: 0.0004 in (0.01 mm)

Particle velocity: 2 to 34 mph (0.9 to 15.5 m/s)

Precipitation types: Rain, snow

Solid precipitation: 0.2 to ~1.8 in (5.1 to ~30 mm)

Reproducibility: Typical > 90% under laboratory conditions

Response threshold: 0.002 mm

Units Available: mm, inches

Tipping Bucket Rain Gauge (601 Model)

Resolution: 0.2 mm (0.007 in)

Accuracy: $\pm 2\%$

Precipitation type: Rain

Units Available: mm, inches

Compass

Measurement Range: 0 to 359°

Resolution: 1.0°

Sampling rate: 5 minutes

Solar Radiation

(501 Model)

Measurement Range: 0.0 to 2,000 W/m²

Resolution <1 W/m²

Response time (95%): 18 seconds

Non-stability (change/year): <1%

Non-linearity (0 to 1,000 W/m²): <1%

Directional error (at 80° with 1,000 W/m²): <20 W/m²

Temperature dependence of sensitivity: <5% (-10 to +40°C)

Tilt error at 1,000 W/m²: <1%

Spectral range (50% points): 300 to 2,800 nm

Maximum irradiance: 2,000 W/m²

(700 & 800 Model)

Measurement Range: 0.0 to 2,000 W/m²

Response time (95%): < 1 sec

Spectral range 300 to 1100 nm

Input Voltage

The Pulsar is supplied with a wall mount switching power supply

Input: 100 to 240 VAC, 50/60 HZ, 0.6A

Output: 24 VDC, 2.5A

The Pulsar can also be powered directly using a DC voltage source

Input: 12 to 24 VDC (1.7 A at 24 VDC) when heater is activated

Heating

The precipitation sensor and wind sensors are heated for operation in winter.

The heater will be enabled when the ambient temperature falls below 41°F (5°C). The heater will maintain a temperature of 122°F (50°C) to prevent the effects of ice and snow on the ultrasonic wind sensor and the Doppler radar precipitation sensor.

Heating Power Source

Input: 12 to 24 VDC (1.7 A at 24 VDC)

To ensure full functionality of the heater, a voltage of 24VDC is advised.

When the sensor is powered at 12VDC the functionality of the heater is limited (i.e., heater may not be able to keep the sensor completely ice-free during winter operation.)

Power Consumption (without heating)

Model	24VDC	12VDC
10	230mA	460mA
100	42mA	82mA
200	16mA	25mA
400	160mA	110mA
500	140mA	80mA
501	145mA	85mA
600	160mA	130mA
601	140mA	85mA
700	160mA	130mA
800	160mA	130mA

Power Consumption (@ 24VDC - with heating)

Model	24VDC	Wattage
100	380mA	9.1W
200	833mA	20W
400	833mA	20W
500	833mA	20W
501	833mA	20W
600	1.7A	40W
601	833mA	20W
700	1.7A	40W
800	1.7A	40W

Dimensions & Weights

Model	Height	Width	Weight
10	5.11 in (130 mm)	5.7 in (145 mm)	1.10 lb (0.5 kg)
100	7.4 in (190 mm)	5.9 in (150 mm)	1.32 lb (0.6 kg)
200	7.6 in (194 mm)	5.9 in (150 mm)	1.76 lb (0.8 kg)
400	10.9 in (279 mm)	5.9 in (150 mm)	2.86 lb (1.3 kg)
500	11.3 in (287 mm)	5.9 in (150 mm)	2.64 lb (1.2 kg)
501	13.07 in (332 mm)	5.9 in (150 mm)	3.3 lb (1.5 kg)
600	13.5 in (343 mm)	5.9 in (150 mm)	3.3 lb (1.5 kg)
601	17.5 in (445 mm)	6.4 in (164 mm)	3.75 lb (1.7 kg)
700	13.5 in (344 mm)	5.9 in (150 mm)	3.3 lb (1.5 kg)
800	13.5 in (344 mm)	5.9 in (150 mm)	3.3 lb (1.5 kg)

Sensor Housing

Protection type: IP66 (Pulsar 10; IP67)

Protection class: III (SELV)

Electrical Conformity

The Pulsar series of sensors conform to the following specific EMC Standards:

EN 61000-6-2:2005Part 6-2: Generic Standards - Immunity for Industrial Environments

EN 61000-4-2 (2009-12) ESD

EN 61000-4-3 (2011-04) Radiated electromagnetic field

EN 61000-4-4 (2011-10) Burst

EN 61000-4-5 (2007-06) Surge

EN 61000-4-6 (2009-12) Conducted disturbances, induced by radio-frequency fields

EN 61000-4-8 (2010-11) Power frequency magnetic field immunity

EN 61000-4-16 (2011-09) conducted, common mode disturbances

EN 61000-4-29 (2001-10) Short interruptions and voltage variations on DC input

EN 61000-6-3:2007Part 6-4: Generic Standards - Emission Standard for Industrial

Environments

EN 55011:2009 + A1:2010 (2011-04) Line-conducted disturbances

IEC / CISPR 11:2009 and changes 1:2010 Class B

prEN 50147-3:2000 Radiated emission

Pulsar Sensors: FCC ID: UF9-WSX00

Pulsar 100: FCC ID: UF9-WS100

Pulsar 10 Specifications

Operating Conditions

Temperature Operation: -40 to +140°F (-40 to +60°C)

Relative humidity: 0 to 100%

Wind Speed

Range: 0 to 90 mph (0 to 40 m/s)

Accuracy: ± 2.2 mph (± 1 m/s) or 5%, the larger value is valid

Units Available: knots, mph, km/hr, m/s

Wind Direction

Measurement Range: 0 to 359.0°

Accuracy: $\pm 10^\circ$

Units Available: degrees

Relative Humidity

Range: 0 to 100%

Accuracy: $\pm 5\%$ @ 68°F and $< 80\%$ RH

Units Available: %RH

Temperature

Range: -40 to +140°F (-40 to +60°C)

Accuracy: $\pm 1.8^\circ\text{F}$ (41 to 140°F), otherwise $< \pm 3.6^\circ\text{F}$

($\pm 1^\circ\text{C}$ (5 to 60°C) otherwise $< \pm 2^\circ\text{C}$)

Units Available: °F, °C

Barometric Pressure

Range: 8.85 to 32.48 inHg (300 to 1100 hPa)

Accuracy: ± 0.015 inHg (0.5 hPa) @ 77°F

Units Available: kPa, hPa, mbar, inHg

Precipitation

Measurement Range: (0 to 0.04 in/hr) (0 to 100 mm/hr)

Accuracy: 20% under laboratory environment

Resolution: 0.0004 in (0.01 mm)

Units Available: mm, inches

Compass

Measurement Range: 0 to 359°

Resolution: 1.0°

Sampling rate: 1 second (mean value over 16 measurements)

Solar Radiation

Measurement Range: 0 to 1,500 W/m²

Accuracy: 10% or ± 120 W/m², larger value is valid

UV Index

Measurement Range: 0 to 15

Dimensions & Weight

8.9 in x 5.7 in x 5.1 in (227 mm x 145 mm x 130 mm)

1.10 lb (0.5 kg)

Tube size diameter: 1.37 in (35 mm)

Sensor Housing

Protection type: IP67

Protection class: III (SELV)

Principles of Measurements

Temperature & Relative Humidity

Temperature is measured by way of a highly accurate NTC-resistor while humidity is measured using a capacitive humidity sensor. To keep the effects of external influences (e.g. solar radiation) as low as possible, the sensors are located in a ventilated housing with solar radiation protection.

Wind Speed & Direction

The wind sensor has no moving parts, which makes it virtually maintenance free. Four ultrasonic sensors are used to continuously collect measurements from all directions. The resulting wind speed and direction are calculated from the measured run-time sound differential.

Pulsar 10 Only

The wind meter uses a heated thermal element. Depending on the wind speed and direction the temperature of the thermal element changes. This temperature change is used to calculate the wind speed and direction.

Barometric Pressure

Absolute air pressure is measured using a built-in capacitive MEMS sensor.

Pulsar 10 Only

The absolute air pressure is measured by an integrated sensor (MEMS) within the device. The sea-level based air pressure is calculated based on the GPS measured elevation of the mounting position.

Precipitation

Doppler Radar

Transmits a 30° conical beam with a 1-meter range above the sensor with a frequency of 24GHz at 18dBm (63 mW).

Precipitation is measured by a 24 GHz Doppler radar, which measures the drop speed of an individual drop of rain or snow. Precipitation quantity and intensity are calculated from the correlation between drop size and speed. The difference in drop speed determines the type of precipitation (rain/snow).

The Doppler Radar sensor can sense (measure) rain drop size between 0.3 mm and 5.0 mm. The sensor responds quickly with a resolution of 0.0004 inches (0.01 mm).

Tipping Bucket Rain Gauge (601 Model)

Rain is measured by the tipping spoon and tipping bucket process.

Solar Radiation

(501 Model)

Pulsar Weather Station 501 model integrates a Kipp+Zonen CMP3 thermopile sensor which measures the solar energy that is received from the total solar spectrum with a 180 degrees field of view. The output is expressed in watts per meter squared.

Rated ISO 9060:1990 Second Class, it is intended for shortwave global solar radiation measurements in the spectral range from 300 to 2800 nm. The thermopile detector measures irradiance up to 2000 W/m² with response time <18 seconds and typical sensitivity 10 μ V/W/m² that varies less than 5 % from -10 °C to +40 °C.

(700 & 800 Model)

Pulsar Weather Station 700 & 800 model integrates a thermopile pyranometer which measures the solar energy that is received from the total solar spectrum with a 180 degrees field of view. The output is expressed in watts per meter squared.

Lightning Detection

The Pulsar Weather Station model 800 includes lightning detection by an integrated sensor which analyzes the radio wave emission of lightning and delivers a count of recognized strikes. The sensor analyzes spectrum and wave form of the received signal to suppress the detection of man-made electrical discharges.

Lightning Detection: Number of lightning events

Coverage Area: 5 to 10 km (3 to 6 miles)

Compass

The integrated electronic compass can be used to check the north-south adjustment of the sensor housing for wind direction measurement. It is also used to calculate the compass corrected wind direction.

Ventilation Fan

To provide more accurate temperature and relative humidity measurements the Pulsar sensor utilizes an airflow fan through the sensor housing. (Excludes Pulsar 10, 100 and 200).

GPS (Global Positioning System) Pulsar 10 Only

An integrated GPS-Module is used to provide the geographical position of the Pulsar 10. Date and time also provided.

SECTION 2: PHYSICAL DESCRIPTION

Pulsar Sensor Transmitter

The Pulsar Sensor Transmitter is an all-in-one sensor available in five unique models. Depending on the model, each device includes a different combination of sensors for measuring a variety of parameters.

All of the Pulsar sensor transmitters except the Pulsar 100 utilize an integrated electronic compass to orient the sensor housing and automatically correlate wind direction.

Each model except the Pulsar 10 is equipped with a heater to prevent the effects of ice and snow during winter operation. The heater is designed to maintain a constant temperature to reduce the accumulation of ice and snow on the wind sensor and the Doppler radar precipitation sensor where applicable.

The Pulsar weather station (excluding the 100 & 200 models) also includes a temperature sensor and a relative humidity sensor inside of a ventilated housing with radiation protection to reduce the effects of solar radiation exposure. A ventilation fan provides air flow circulation through the sensor housing for higher accuracy temperature and relative humidity readings.

Please reference the chart below to identify your specific model.

Sensors by Model #	10	100	200	400	500	501	600	601	700	800
Temperature	X			X	X	X	X	X	X	X
Relative Humidity	X			X	X	X	X	X	X	X
Barometric Pressure	X			X	X	X	X	X	X	X
Wind Speed	X		X		X	X	X	X	X	X
Wind Direction	X		X		X	X	X	X	X	X
Precipitation	X	X		X		X	X	X	X	X
Compass	X		X		X	X	X	X	X	X
Solar Radiation	X					X			X	X
Lightning Detection										X

Pulsar 10

The Pulsar 10 Sensor features a Doppler Radar precipitation sensor. A heated thermal element is used to measure wind speed and direction. A silicon pyranometer provides the solar irradiance measurement. Using solar irradiance and other measurements the sensor provides a calculated UV Index. An integrated GPS unit provides geographical position of the sensor. The Pulsar 10 also includes a pressure sensor, temperature sensor and relative humidity sensor.

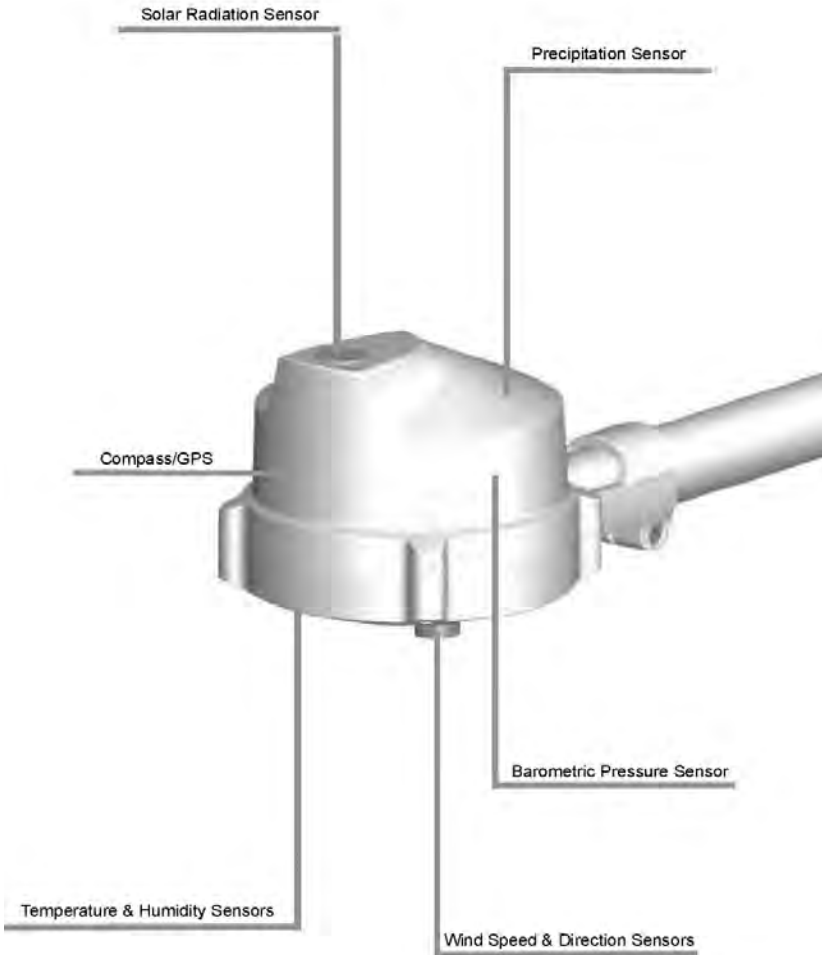

Dimensions

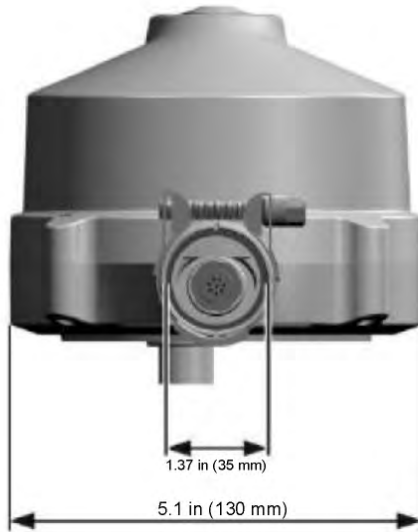
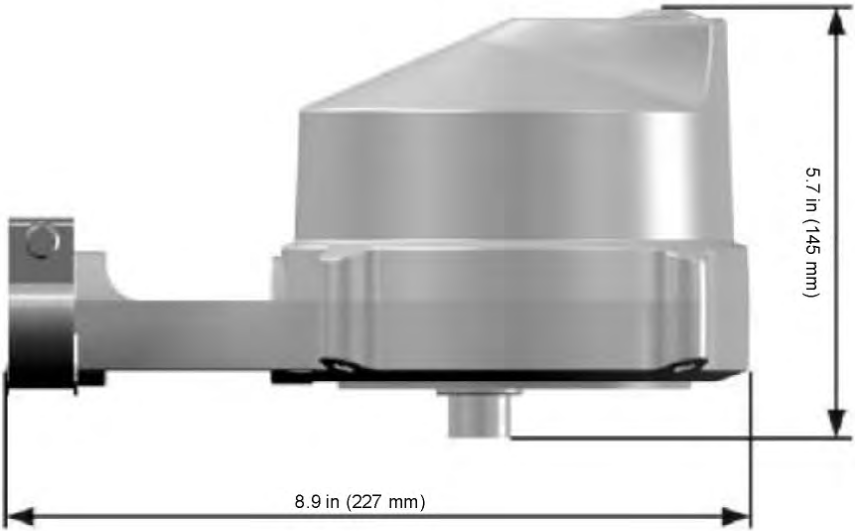

Pulsar 100

The Pulsar 100 features a Doppler Radar precipitation sensor.

The precipitation sensor operates at 24 GHz and can measure the speed of all forms of condensed water. These include rain, freezing rain, hail, snow and sleet.

Snowfall is measured as accumulated rainfall.

The Doppler Radar sensor can measure rain drop size between 0.3 mm and 5.0 mm.

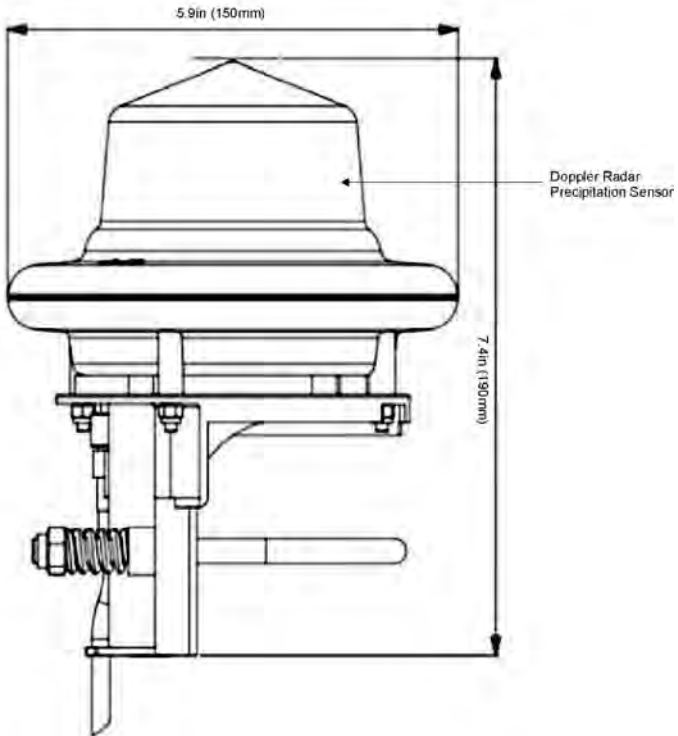

Pulsar 200

The Pulsar 200 features an ultrasonic wind sensor for precision wind speed and direction measurements.

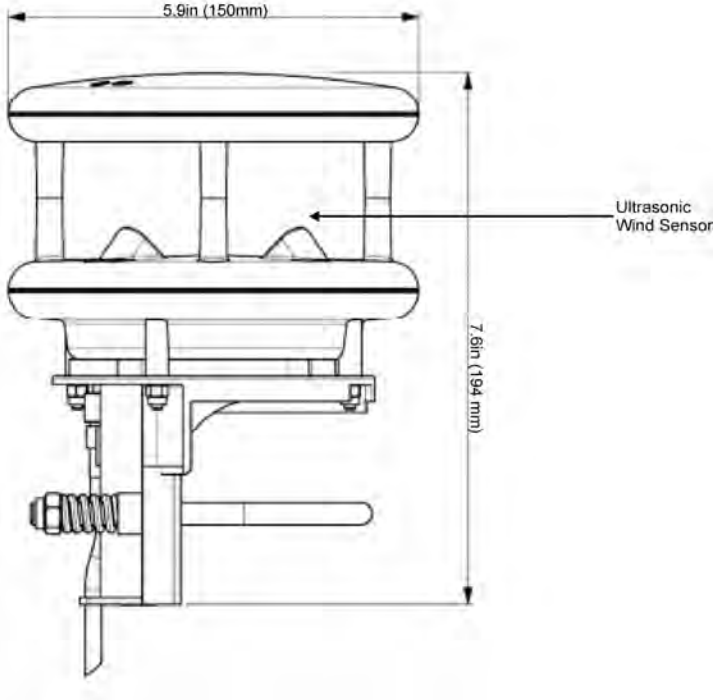

Pulsar 400

The Pulsar 400 features a Doppler Radar precipitation sensor that operates at 24 GHz and can differentiate between solid and liquid precipitation (i.e., rain, snow). Snowfall is measured as accumulated rainfall.

Due to the precipitation sensor's high resolution the 400 model is well suited for applications where precipitation detection is critical.

The Doppler Radar sensor is able to sense (measure) rain drop sizes between 0.3 mm and 5.0 mm.

A built-in pressure sensor measures barometric pressure. The 400 model also includes a temperature sensor and a relative humidity sensor inside a ventilated housing.

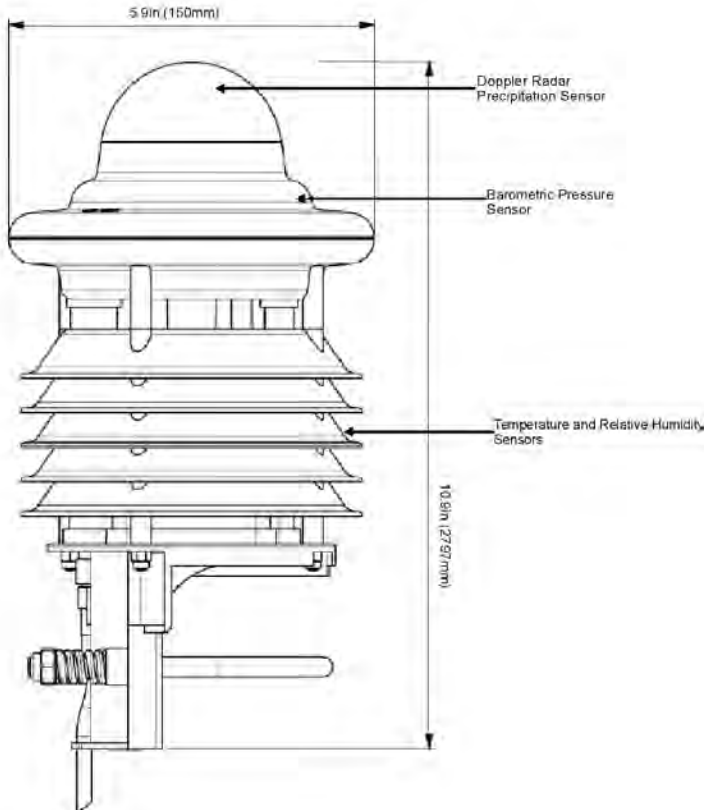

Pulsar 500

The Pulsar 500 features an ultrasonic wind sensor for precision wind speed and direction measurements, and a barometric pressure sensor. The 500 model also includes a temperature sensor and a relative humidity sensor inside a ventilated housing.

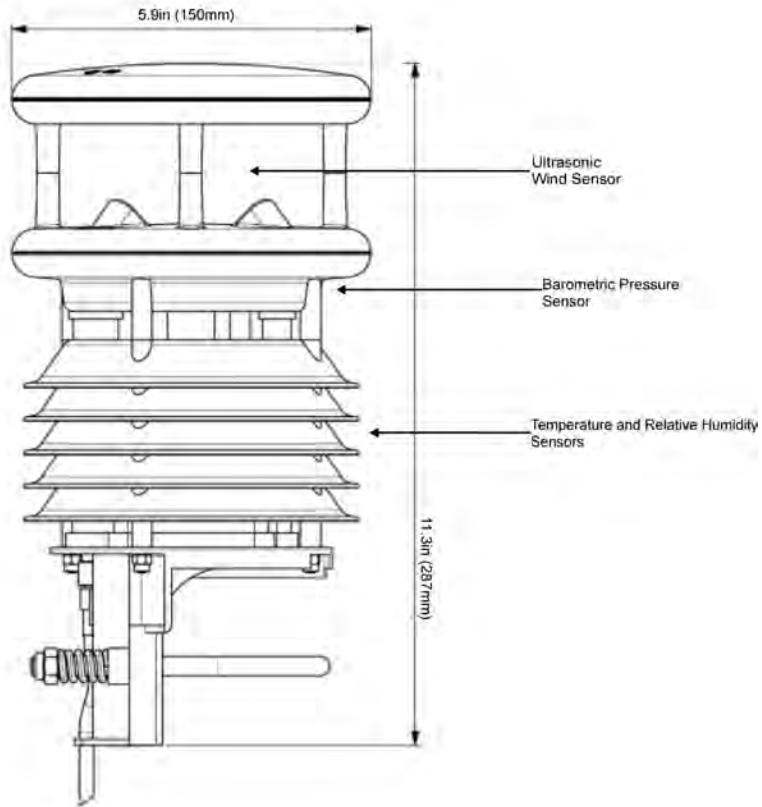

Pulsar 501

The Pulsar 501 features a Second-Class solar radiation sensor. An ultrasonic wind sensor is used to measure wind speed and direction. A built-in pressure sensor measures barometric pressure. The 501 model also includes a temperature sensor and a relative humidity sensor inside a ventilated housing.

The 501 model integrates the Kipp+Zonen CMP3 thermopile sensor which measures the solar energy that is received from the total solar spectrum with 180 degrees field of view. The output is expressed in Watts per meter squared.

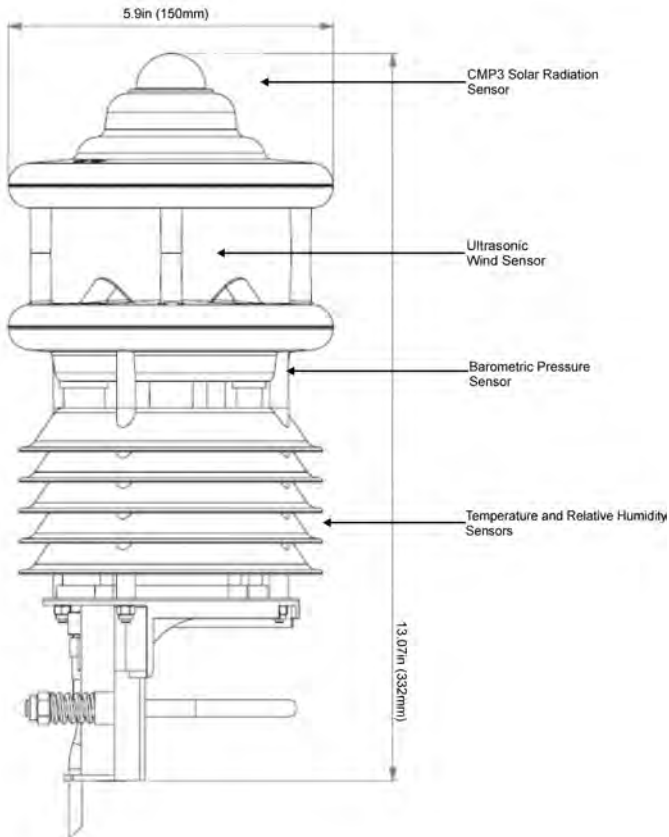

Pulsar 600

The Pulsar 600 features a Doppler Radar precipitation sensor. An ultrasonic wind sensor is used to measure wind speed and direction. A built-in pressure sensor measures barometric pressure. The 600 model also includes a temperature sensor and a relative humidity sensor inside a ventilated housing.

Due to the precipitation sensor's high resolution the 600 model is well suited for applications where precipitation detection is critical.

The precipitation sensor operates at 24 GHz and can differentiate between solid and liquid precipitation (i.e., rain, snow). Snowfall is measured as accumulated rainfall.

The Doppler Radar sensor is able to sense (measure) rain drop sizes between 0.3 mm and 5.0 mm.

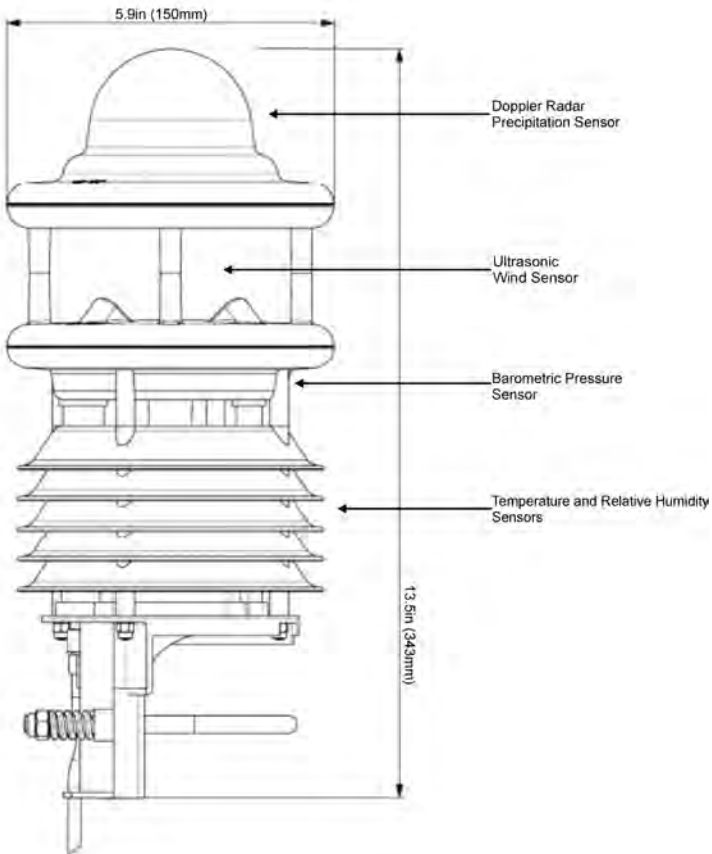

Pulsar 601

The 601 model utilizes a tipping-bucket rain gauge to measure rainfall accumulation. An ultrasonic wind sensor is used to measure wind speed and direction. A built-in pressure sensor measures barometric pressure. The 601 model also includes a temperature sensor and a relative humidity sensor inside a ventilated housing.

The function of the rain gauge will be significantly influenced by pollution of the funnel or the tipping bucket mechanism. Routine inspection and cleaning, if required, is recommended. The tipping bucket should be kept free of debris, leaves, dust, dirt, pollen, etc.

Only clean when obviously polluted; avoid moving the tipping mechanism to prevent false tips.

Best practice is to disconnect the sensor cable when cleaning to avoid faulty precipitation amounts. Use water and a soft cloth for cleaning.

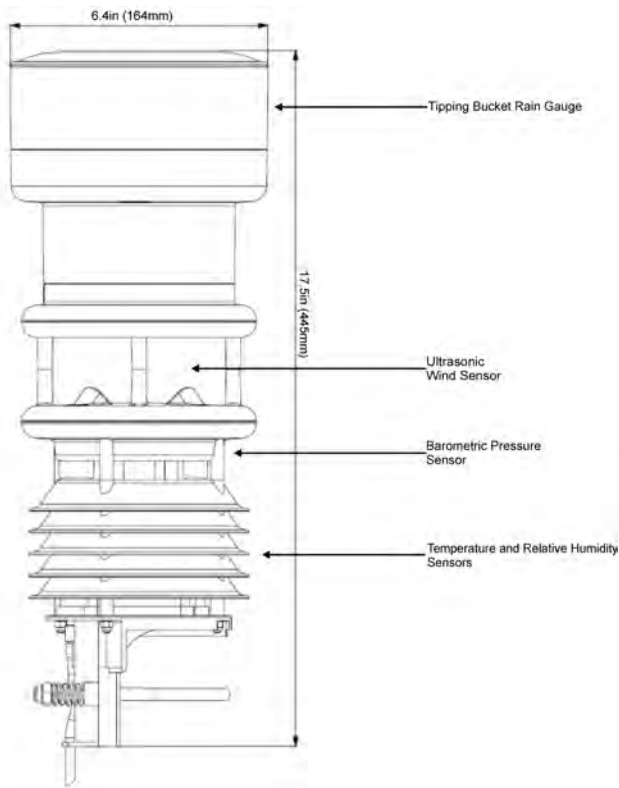

Pulsar 700

The 700 model features a thermopile pyranometer to measure global radiation. An ultrasonic wind sensor is used to measure wind speed and direction. A built-in pressure sensor measures barometric pressure. The 700 model also includes a temperature sensor and a relative humidity sensor inside a ventilated housing.

The 700 model integrates a thermopile sensor which measures the solar energy that is received from the total solar spectrum with 180 degrees field of view. The output is expressed in Watts per meter squared.

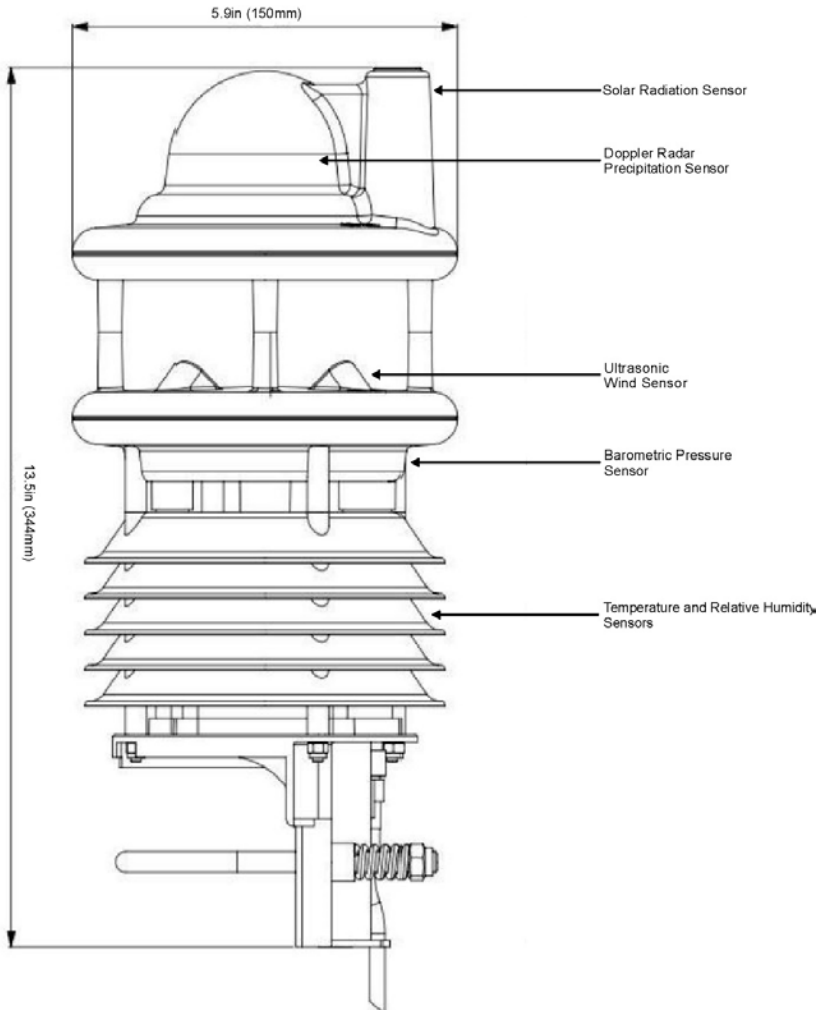

Pulsar 800

The 800 model features a thermopile pyranometer to measure global radiation. An ultrasonic wind sensor is used to measure wind speed and direction. A built-in pressure sensor measures barometric pressure. The 800 model also includes a temperature sensor and a relative humidity sensor inside a ventilated housing.

The 800 model integrates a thermopile sensor which measures the solar energy that is received from the total solar spectrum with 180 degrees field of view. The output is expressed in Watts per meter squared.

The 800 model also includes a lightning detection sensor to provide the number of lightning events in a 5 to 10 km (3 to 6 miles) radius.

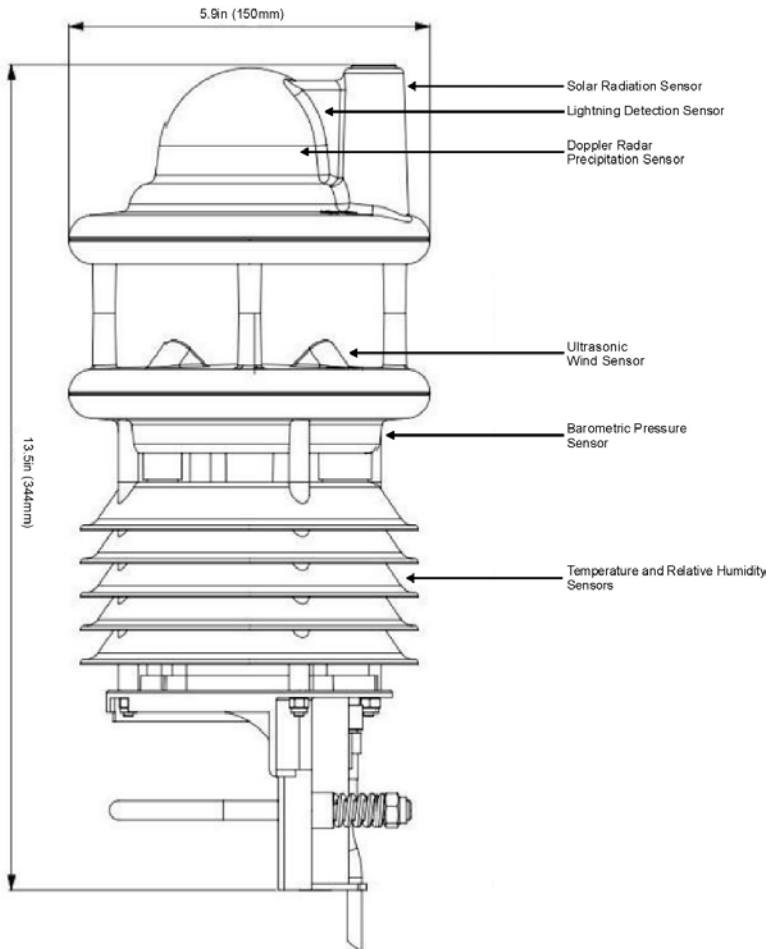

Interface Module

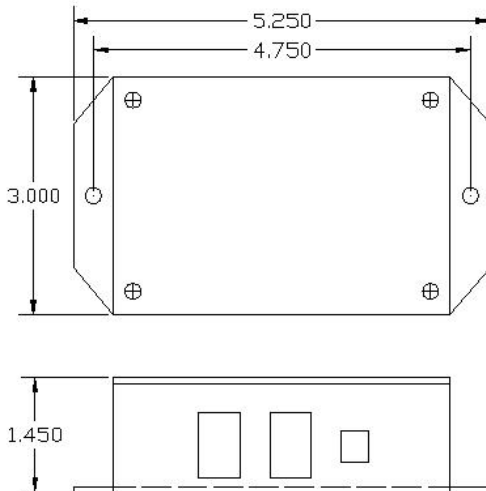

The Interface Module is used to supply power to the sensor transmitter and to provide two RS-232 communication ports. The RS-232 ports can be connected to computers, display consoles, transceivers, and other such devices.

The Interface Module has two LED indicators. The green LED is a power indicator and the red LED is a data indicator. In normal operation, the red LED will be solid to indicate a data record being transmitted. The green LED will also be solid to indicate power is being supplied to the Pulsar sensor transmitter.

Surge/Lightning Protector



A nearby lightning strike may induce a high voltage surge which the internal suppressor of your weather instrument may not be able to withstand, causing significant damage to the weather station. This compact transient overvoltage suppressor is designed for weather stations in areas with an elevated risk of lightning strikes such as the top of high buildings, or installations with cable lengths greater than 100 feet.

- Superior 3-stage surge protection
- Tolerates up to 10kA surge currents
- Both differential and common mode protection on each channel
- Filtering against HF and RF noise
- Two power channels and two data channels
- Environmental protection class IP66

Part Number: 8355-1
Includes adjustable mounting kit

Weather MicroServer (Required)

The Weather MicroServer uses a small computer board that runs an embedded operating system.

The MicroServer has 128MB Flash memory for operation and 8 GB SD card for data logging.

The Pulsar transmitter connects to the MicroServer via RS-485 Serial Communication on COM2.

The Pulsar transmitter can also connect to the RS485 ports on the Top Panel of the MicroServer.



The MicroServer offers the following:

- One year of data logging at 1-minute interval
- Modbus/TCP, Modbus RTU (Serial RS-485) interfaces
- SNMP, BACnet, DNP3 Ethernet & Serial interfaces
- Weather Underground & CWS Weather Server interface
- XML Weather Data
- FTP weather data in XML or CSV format
- CWOP interface
- Interface to optional visibility, solar radiation sensors, and temperature sensors

Please refer to the Weather MicroServer user manual for more information.

WeatherMaster™ Software (Optional)

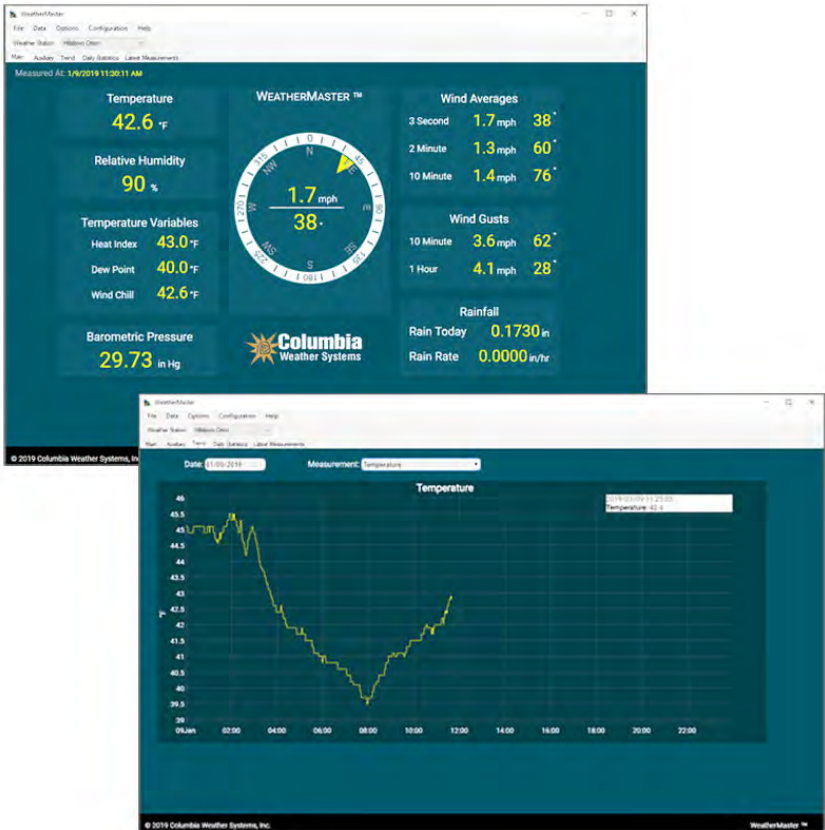

WeatherMaster is professional grade weather monitoring software. This software package is designed for specialized markets that require robust weather calculations, interoperability with computer models, and data interfaces to other industrial systems. WeatherMaster utilizes Microsoft Access database for easy data access and manipulation.

WeatherMaster software communicates with the Pulsar transmitter via the Weather MicroServer.

Please refer to the WeatherMaster user manual for installation and operation procedures.

Weather Display Console (Optional)



Displays weather information • Designed to be viewed clearly from a distance • Industrial grade WVGA touchscreen.

Seven-inch, TFT color LCD panel with 800 x 480 pixel resolution.

Performs computations for wind chill, heat index and other calculated parameters • 800MHz ARM9 CPU

Serial or Ethernet connection: Connects directly to weather station with serial port or connects to a Weather MicroServer over a network utilizing an existing Ethernet infrastructure -- no extra wiring. The MicroServer configuration also allows for data from one weather station to be monitored from multiple display consoles at various locations.

Screens can be factory-customized to meet specialized market and industry requirements.

The Weather Display is also available in a 19" rack-mount chassis and a panel-mount configuration.

The Weather Display Console communicates with the Pulsar transmitter via the Weather MicroServer.

Please refer to the Weather Display Console user manual for more information.

SECTION 3: SYSTEM CONFIGURATIONS

The Pulsar Fixed Mount Weather Station can be installed in multiple configurations depending on communication options, power availability and viewing options. The output signal of the Pulsar transmitter is UMB binary over an RS-485 serial port.

Cabled System COM2 Connection

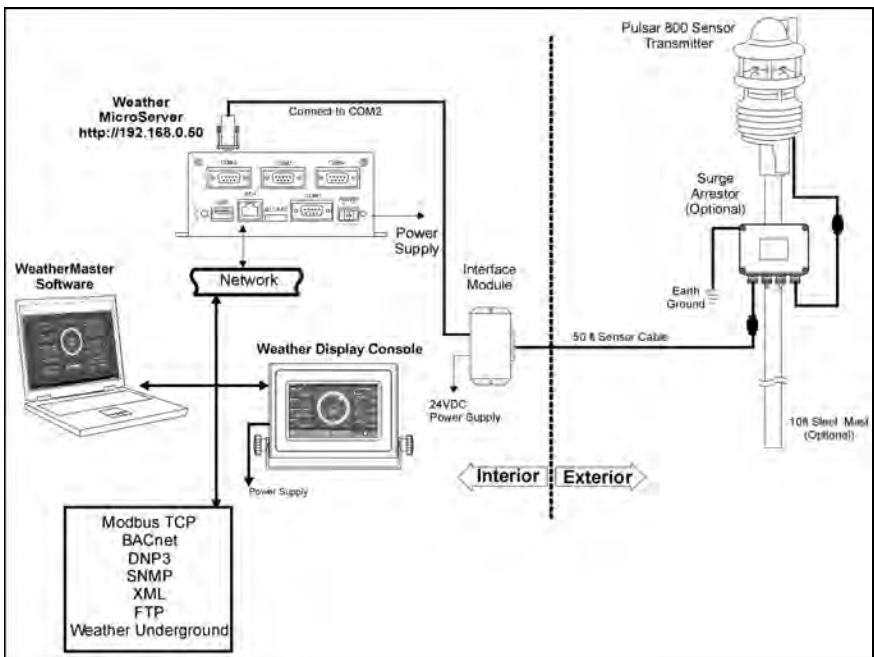

Cabled System COM1 Connection

If COM2 on the MicroServer is used for other interfaces or sensors, the Pulsar can connect to either COM5 or COM7 on the Top Panel of the MicroServer.

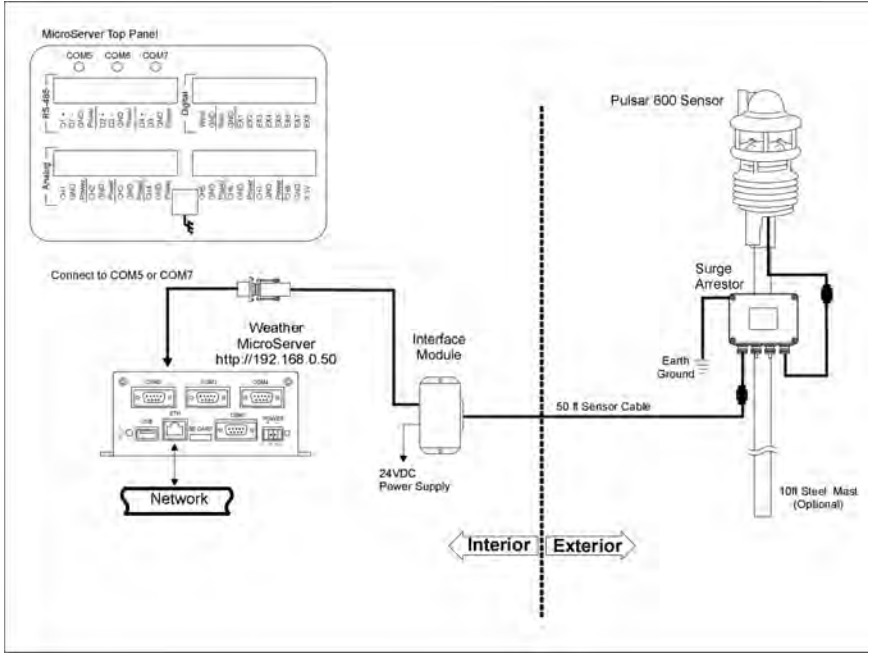

System with Weatherproof Enclosure

For outdoor installations, the MicroServer can be housed in a 12"x10"x6" weatherproof enclosure.

The system enclosure includes a 24VDC power supply, mounting panels, Interface Module, and terminal blocks for sensor connections as well as optional hardware to mount the enclosure onto a mast.

The enclosure also includes a connection diagram.

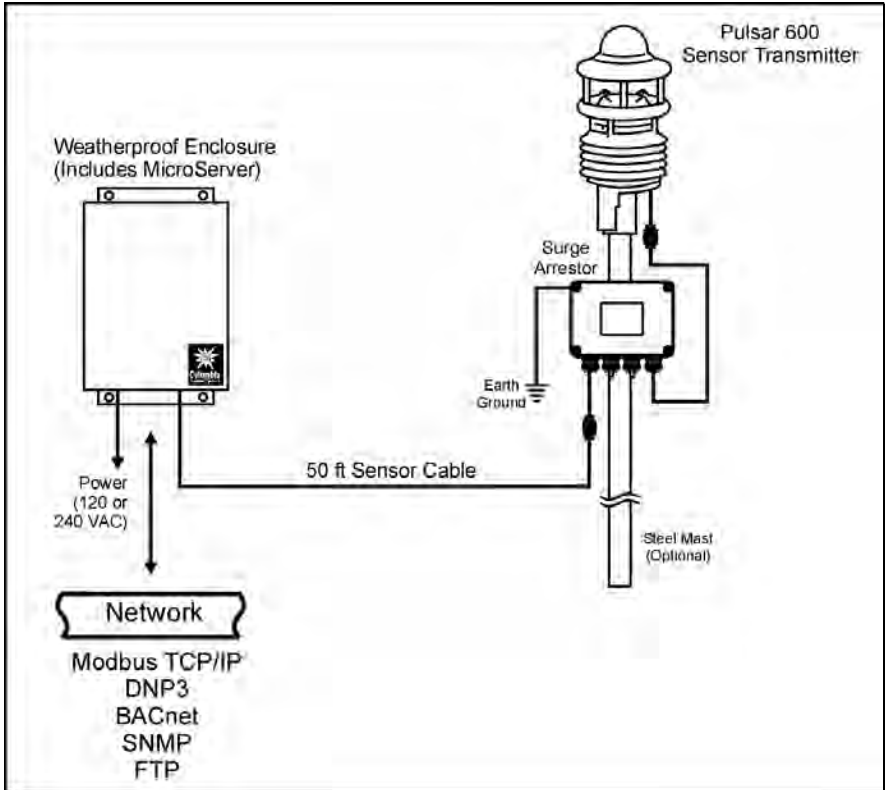

Wireless System with Weatherproof Enclosure:

Following is an example of a wireless configuration.

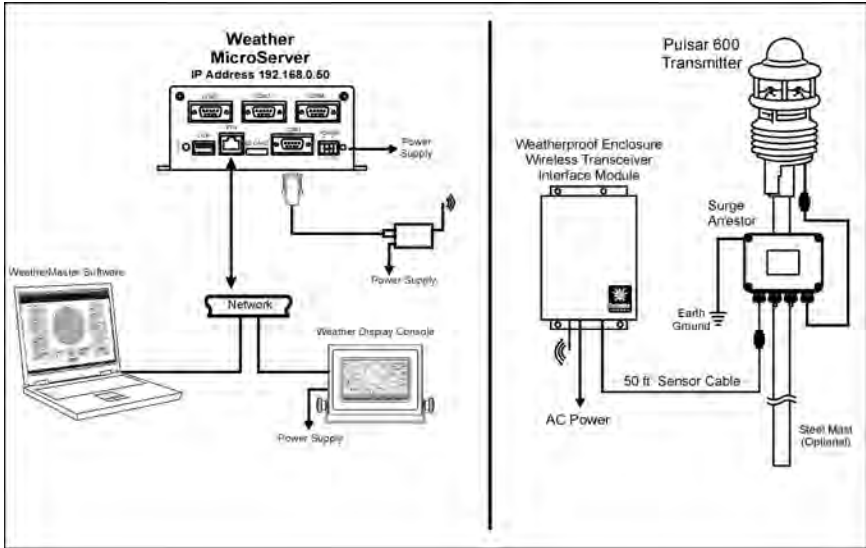

The server transceiver is located near the Pulsar sensor head and is housed in the weatherproof enclosure. A client transceiver is connected to the monitoring device. An RS-232 Interface Module is available as an option to connect the wireless transceiver to multiple devices.

The 2.4GHz transceivers are capable of communicating at a distance of 1 mile with a clear line-of-sight.

The 900MHz transceivers are capable of communicating at a distance of 20 miles with a clear line-of-sight.

During normal operation the wireless transceiver pair will function as follows:

Transmitter (2.4GHz)

Red Power LED: Blinks Twice/Second

Green TX (Transmit) LED: Blinks Once/Second

Yellow RX (Receive) LED: OFF

Signal Strength: OFF

Receiver (2.4GHz)

Red Power LED: Blinks Twice/Second

Green TX (Transmit) LED: OFF

Yellow RX (Receive) LED: Blinks Once/Second

Signal Strength: All three LEDs should be lit depending on line-of-sight.

Transmitter (900MHz)

Red TX/Power LED: ON Solid

Green Data In LED: Blinks Once/Second

Yellow Data Out LED: OFF

Signal Strength: OFF

Receiver (900MHz)

Red TX/Power LED: ON Solid

Green Data In LED: OFF

Yellow Data Out LED: Blinks Once/Second

Signal Strength: All three LEDs should be lit depending on line-of-sight.

4-20mA Industrial Interface

The Pulsar series of sensors can also be configured to output a 4-20mA current signal to interface with a PLC.

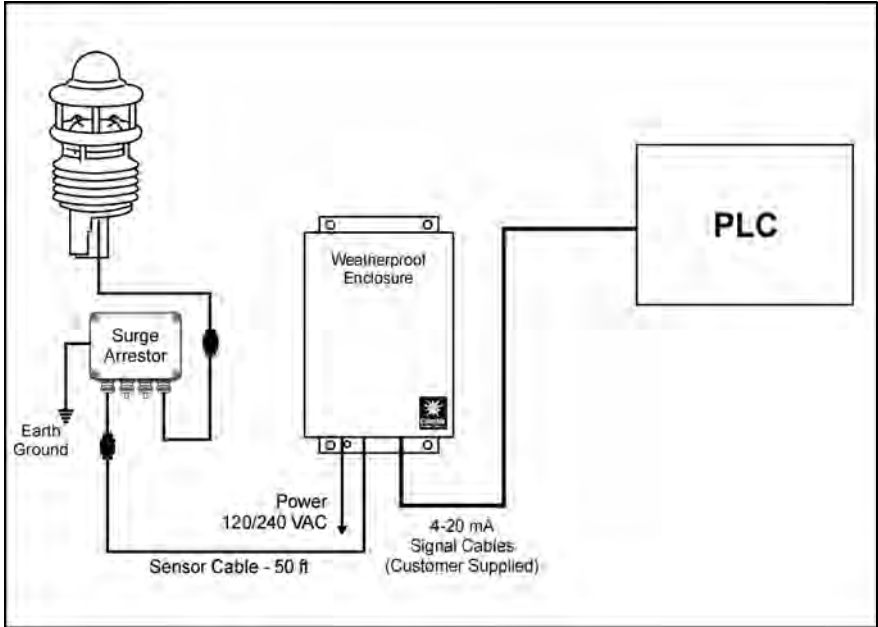

The Pulsar with 4-20mA interface consists of the Pulsar Sensor Transmitter, 50ft cable and weatherproof enclosure. The enclosure includes a 24VDC power supply, digital-to-analog converter and terminal blocks for connections.

The Digital-to-Analog Converter converts the Pulsar signal to 4-20mA current signals.



Weatherproof Enclosure

The Digital-to-Analog Converter is housed in a weatherproof enclosure along with the power supply.

The enclosure also includes terminal blocks to connect the Pulsar sensor to the Digital-to-Analog Converter.

The 4-20mA current signals are available on the terminal blocks and are labeled as Output 1, 2, 3, etc.

The 4-20mA current signals source power to the PLC, no need to provide power to the Output channels.



4-20mA Output Scaling

Depending on the specific model of Pulsar Sensor that was ordered the current outputs will be configured appropriately.

See the system diagram provided with your system for the appropriate scaling. The output scaling is also provided on the inside lid of the weatherproof enclosure.

Below is an example of the scaling for the Pulsar 600 Sensor.

The measurements update every second.

Output 1: Wind Direction

Range: 0 to 360°

Output 2: Wind Speed

Range: 0 to 167 mph

Output 3: Temperature

Range: -58 to 140°F

Output 4: Relative Humidity

Range: 0 to 100%

Output 5: Barometric Pressure

Range: 8.85 to 35.4 inches Hg

Output 6: Precipitation Amount

Range: 0 to 3.940 inches

Description: Accumulated rain value

Snow, sleet, hail, and freezing rain are measured as the water equivalent of rainfall accumulation.

Note: Resets to zero every 10 seconds or if power is lost to the sensor.

Output 7: Precipitation Intensity

Range: 0 to 7.870 inches/hour

Note: Resets to zero if power is lost to the sensor.

Output 8: Precipitation Type

Range: 0 to 255

Precipitation Type is displayed as a code. Please reference the chart below to decipher the code.

Precipitation Type	Code
No precipitation	0
Unspecified precipitation	40
Liquid precipitation; rain	60
Solid precipitation; snow	70
Freezing Rain	67 (Pulsar 100 only)
Sleet	69 (Pulsar 100 only)
Hail	90 (Pulsar 100 only)

SECTION 4: INSTALLATION

Installation Overview

Unpacking the System

Installing the Sensor Transmitter

Installing the Mast

Installing the Mounting Adapter

Installing the Surge Arrestor

Connecting the Sensor Transmitter to the Interface Module

Connecting to MicroServer, Weather Display and Computer (refer to Section 3: System Configurations)

Unpacking the Unit

Unpack the Pulsar weather station and verify that all parts are included.

1. Standard system includes:

- Pulsar Sensor Transmitter
- 50 ft sensor cable + additional cable length if ordered
- Interface Module with (2) 3-position terminal blocks
- 24VDC power supply
- User Manual
- 6-foot RS-232 cable + additional cable length if ordered
- Mounting Adapter with Hex Key

2. Weather MicroServer:

- MicroServer
- Power supply
- 7-foot Ethernet cable
- User manual

3. Surge Arrestor

- Surge Arrestor
- Mounting Hardware

4. Weather Display Console (Optional)

- Display Console
- Power supply
- 6-foot RS-232 cable + additional cable length if ordered
- User manual

5. WeatherMaster software and user manual (Optional)

Inspect all system components for obvious shipping damage (Refer to “Important Notice: Shipping Damage” in case of damage).

NOTE: Save the shipping carton and packing material in case the unit needs to be returned to the factory. If the system does not operate or calibrate properly, see **Maintenance** and **Troubleshooting** sections, for further instructions.

Installing the Pulsar Sensor Transmitter

Site Selection:

Finding a suitable site for the sensor transmitter is important in obtaining representative ambient measurements. The site should represent the general area of interest.

The sensor transmitter should be installed in a location that is free from turbulence caused by nearby objects, such as trees or buildings.

Ensure the Pulsar 600 sensor is not installed near other devices that may be transmitting at 24GHz; measurement error may occur. Keep the Pulsar at least 16ft away from other communication devices.

WARNING: To protect personnel (and the device), a lightning rod should be installed with the tip at least 40 inches (one meter) above the sensor transmitter. The rod must be properly grounded, compliant with all local applicable safety regulations.

Installing the Mast

There are three acceptable methods for mounting the mast to a roof or building structure: Sloped roof mounting, flat roof mounting or wall mounting. See **Optional Sensor Mounting Hardware** for more information.

Location

Do not attach the sensor transmitter to a radio transmitting mast or tower.

Select a mounting location that will allow the sensor cable to be routed away from other data cables to avoid interference. Do not mount sensors close to power lines. For normal roof mounting, the recommended minimum distance from power lines is 25 ft. (8 m). Use extreme caution when working close to power lines.

Mounting Method

Choose the appropriate mounting method for the installation and obtain any necessary mounting hardware. Refer to Optional Sensor Mounting Hardware section for information on optional sensor mounting hardware and accessories which are available from the factory.

If the mounting hardware is not obtained from the factory, be certain to use metal parts which are plated or galvanized to assure maximum longevity.

Secure the mast to the roof, using guy wires with sufficient tensile strength or to building wall using a wall-mount hardware kit.

Routing Cable

Use plastic tie wraps to secure the cable to mast, particularly at the mast base. Tighten the tie wraps securely and clip off any excess length with a wire cutter tool.

Once the Pulsar sensor transmitter has been placed, route the cable back to the Interface Module or weatherproof enclosure.

CAUTION: There may be electric wires in the wall. When routing cable through walls, we recommend that you shut off the electricity in the room(s) where you are drilling.

Any mast or tower should always be properly earth grounded to minimize electrical storm damage. The use of a properly grounded metal mast or tower, however, does not insure protection from electrostatic discharge. These items could become electrically charged resulting in damage to the sensors and/or console. This could damage the system in the event of an electrical storm.

Note: If the standard 50 ft. cable provided with the sensor transmitter is not long enough, it may be extended by splicing on an appropriate length of 22-gauge, stranded, seven conductor shielded cable with the same color code. When cutting and splicing, insure good contacts, proper color coding of the terminal leads, and a good seal. (A good solder splice, and water proof insulation are essential; merely twisting the respective wires together is not adequate.) Additional cable (Part No. 81547) is available from the factory.

Sensor Mounting Hardware

(excludes Pulsar 10 Sensor, see Pulsar 10 Installation section)

U-Bolt Mounting Bracket

The U-bolt mounting bracket is designed to be installed on the top of a mast with a diameter of 2.3 – 3 inch.

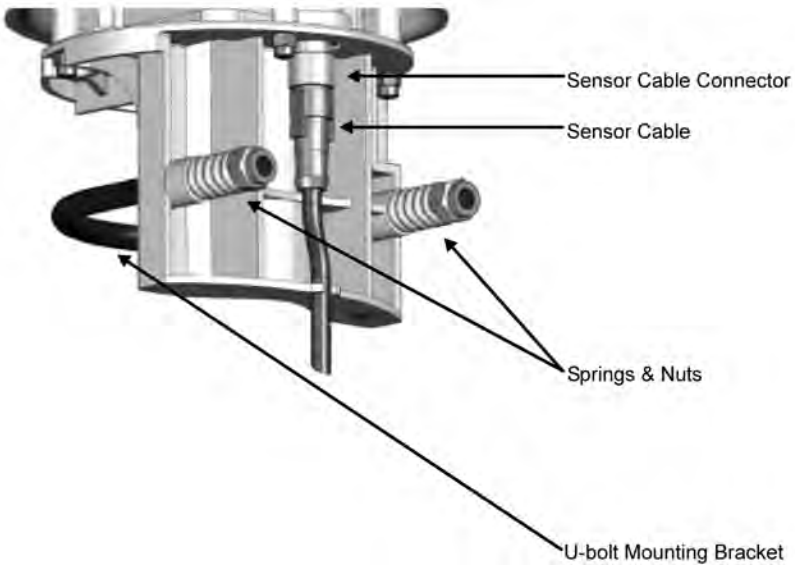

If the standard steel or fiberglass mast was provided with the weather station, then the mounting adapter will be needed.

Mounting Adapter

The mounting adapter is available to fit onto a mast with a 1 to 1.13 inch outside diameter.

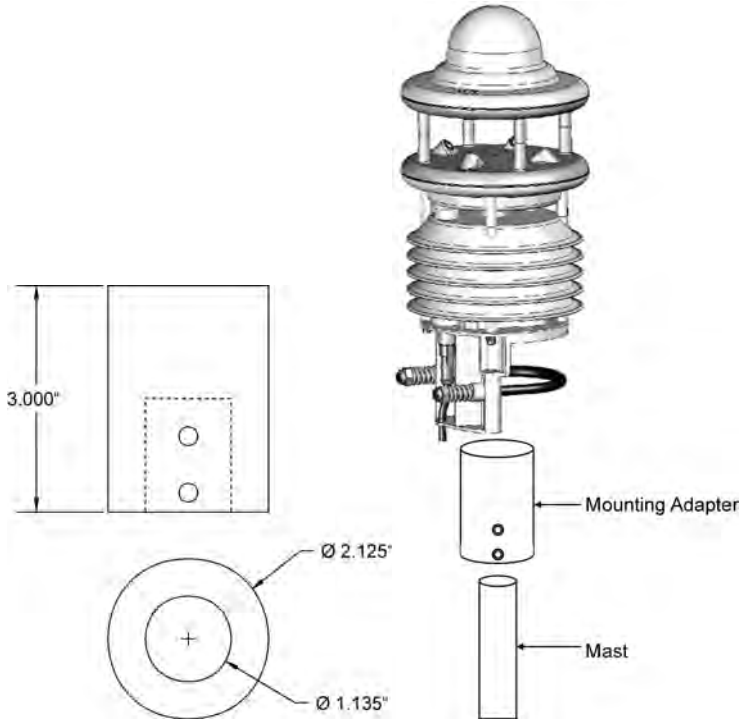

Installation Procedure

1. If being used, insert the mounting adapter onto the mast and tighten the set screws with the hex key provided.
2. Loosen the nuts on the U-bolt mounting bracket.
3. Carefully place the transmitter onto the mast.
4. Tighten both nuts.

Installation procedure is the same for all Pulsar models except Pulsar 10. WS-600 Model shown as an example.

North Alignment – Integrated Electronic Compass

The integrated electronic compass will automatically correct the wind direction. To compensate for the difference between True North and Magnetic North the Magnetic Declination can be entered into the MicroServer. Please see the MicroServer user manual for more information.

Manual North Alignment (Optional Procedure)

The Pulsar sensors are configured to utilize the integrated electronic compass to automatically align the sensor to magnetic north. Manual north alignment is not needed unless the electronic compass is disabled.

In order for the wind direction to display correctly, the sensor must be aligned to True North. The sensor has two directional arrows for this purpose.

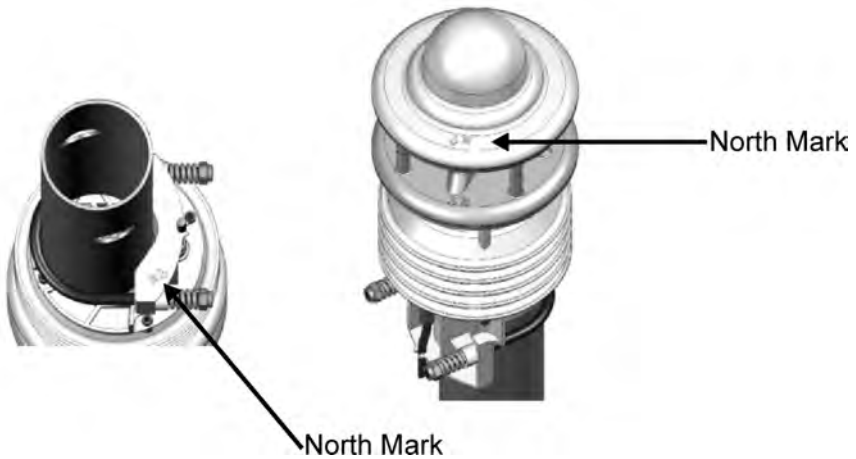

Wind direction can be referenced to true north, which uses the earth's geographic meridians, or magnetic north, which is read with a magnetic compass. The magnetic declination is the difference in degrees between the true north and magnetic north.

North Alignment

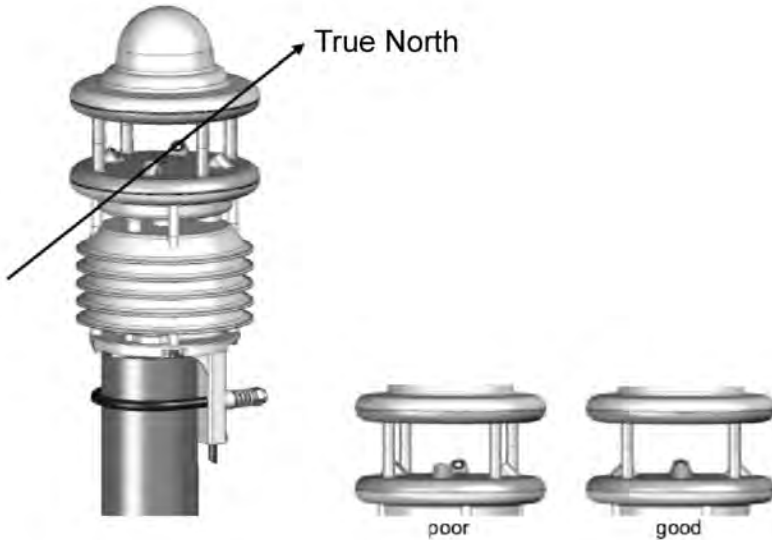

1. If the sensor is already installed, first loosen both nuts evenly until you can turn the sensor easily.
2. Using a compass, identify North and fix a point of reference on the horizon.
3. Position the sensor in such a way that the South and North sensors are in alignment with the fixed point of reference in the North.
4. Tighten both nuts. Once the sensor transmitter is aligned to north, the transmitter can be removed from the mounting adapter without losing the north orientation.

Installing the Surge Arrestor

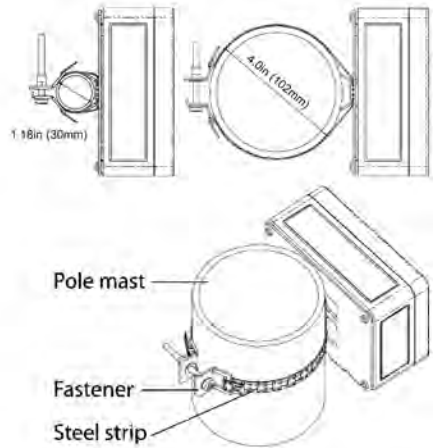
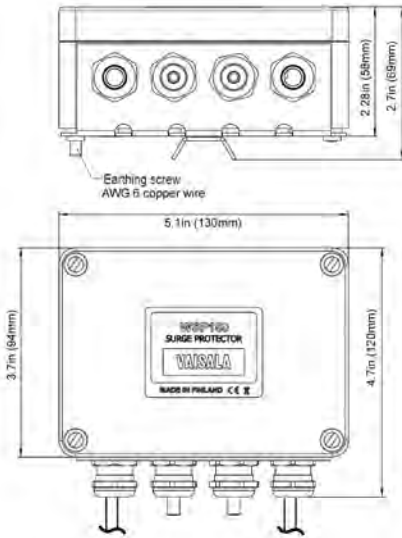

1. Attach the unit to the mast close to the weather sensor with the adjustable mounting clamp, see figure above.
2. Slide the steel strip beneath the latch on the back of the enclosure.
3. Wrap the steel strip around the pole mast. You may shorten the strip to a suitable length.
4. Loosen the fastener by backing up the screw half way.
5. Attach the steel strip ends to the fastener by latching the fastener to a hole on the strip and folding it over.
6. Tighten the fastener's screw in order to secure the unit to the pole.
7. If the mast is not grounded, ground the unit using the grounding screw located on the back of the unit with an AWG 6 (16 mm²) copper wire.

Connecting the Sensor Transmitter to the Interface Module

Using a #1 Straight Slot screwdriver, attach the wires from the end of the sensor cable to the terminal block screws on the Interface Module as follows:

Terminal Number	Function	Color
1	+24 V	RED & Brown*
2	Ground	White, Bare & Blue*
3	No Connection	
4	No Connection	
5	RX	Black
6	TX	Orange

* For optional heater

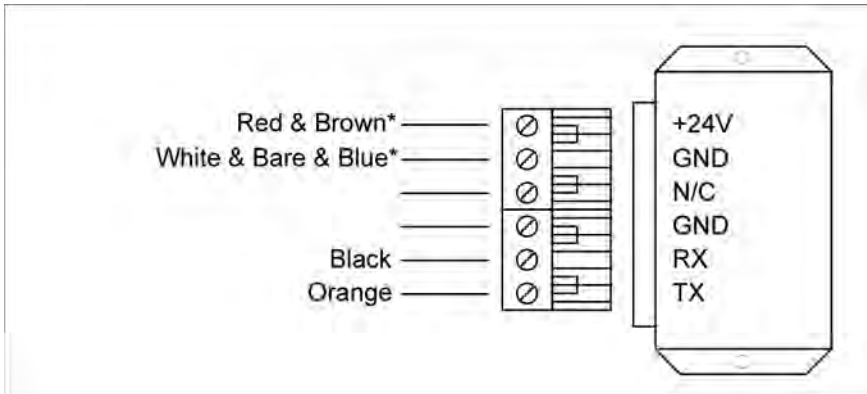

*For the optional heater, connect the brown wire along with the red wire to position 1 and connect the blue wire along with the white and bare wires to terminal 2.

For connecting the sensor transmitter to the weatherproof enclosure, please refer to the Weatherproof Enclosure Wiring Diagram in Section 3.

Optional Sensor Mounting Hardware

Tripod and Tiedown Kit



The tripod is designed to provide up to 10 feet of stable, secure support for your meteorological sensors.

Constructed from welded aluminum and powder coated for appearance and longevity, the 15-pound tripod can easily support up to 60 pounds of equipment. An optional tie-down kit allows for additional security in high-wind areas.

To install, insert the legs into the main body and secure with stainless steel retainer pins. Extend the mast to the desired height and insert another retainer pin. Install the guy wires to complete the set-up.

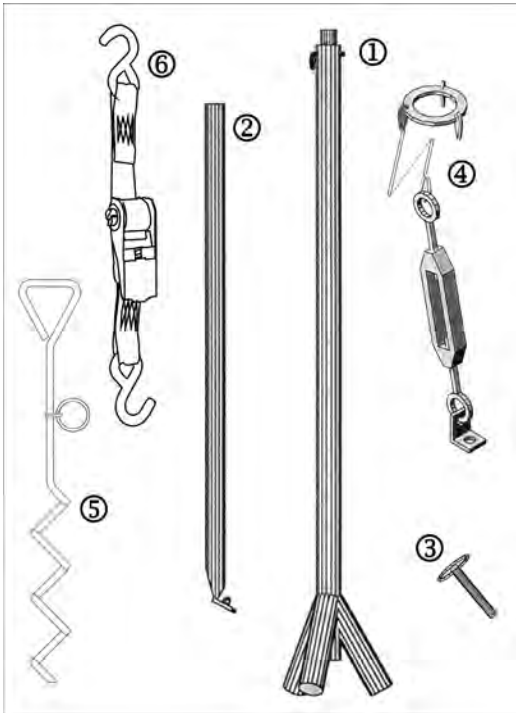
Tripod Parts List:

Description	Ref.	Qty.
Body/Mast Assembly	1	1
Legs	2	3
Retainer Pins	3	4
Guy Wire Ring with 3 Wires and Turnbuckles	4	1
Anchor Screw with Chain	5	1
Clamp with Strap	6	1

Specifications

Capacity: Supports up to 60 lbs.

Shipping Weight: 17 lbs

Shipping Box Dimensions: 71" x 9" x 9"

Tripod and Tiedown Kit Part Number: 88019

Sensor Mast

10-foot steel mast available for use with Roof Mount Hardware Kit (Part No. 88002) or Wall Mount Kit (Part No.88003).

Roof Mounting

The Roof Mount Kit (Part No. 88002) is suitable for both a slanted and flat roof installation. The figure and table below illustrates and describes the individual parts.

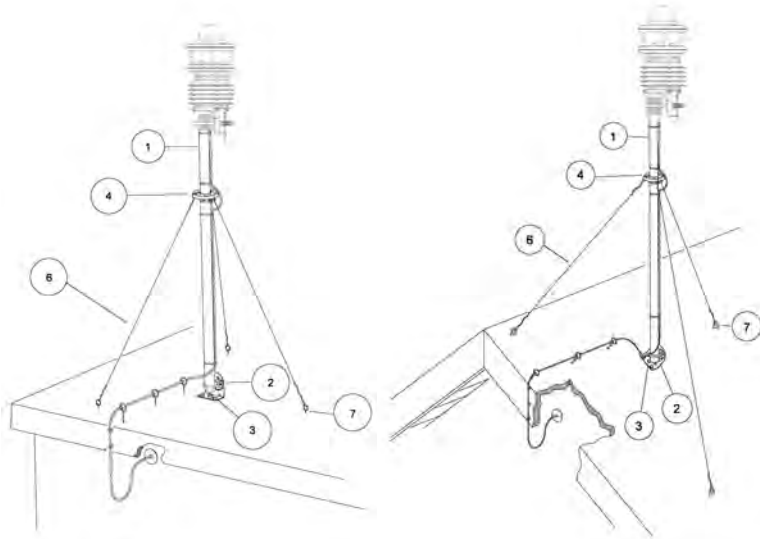

Description	Ref.	Qty.	Part No.
Steel mast, 10 ft.	1	1	88005
Universal Mast Anchor	2	1	88010
Lag Screw, Roof Mast Mount 1/4" x 2 1/4" (for comp. roofs)	3	4	88030
Guy Wire Clamp, 1/8"	4	1	88070
Steel Guy Wire, Galvanized	6	50ft.	88080
Eye Bolt Wood Screws, 1/4" x 3"	7	4	88090
Turnbuckles, 6" open x 4" closed (not shown)	3		88100

Wall Mounting

The figure and table below illustrates and describes the individual parts in the Wall Mounting Kit (Part No. 88003). Individual parts are also available.

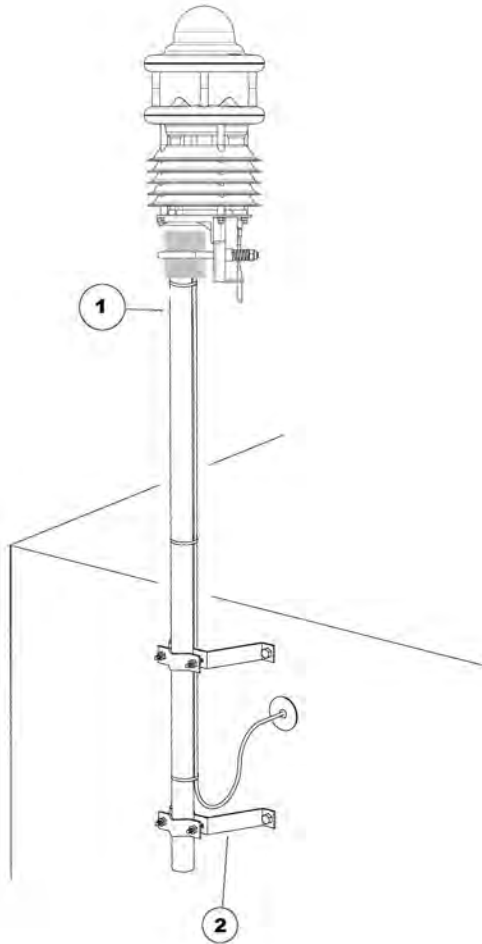

Description	Ref.	Qty.	Part No.
Mast, 10 ft.	1	1	88005
4" Wall Mount Bracket	2	2	88120



EYE BOLT SCREW



UNIVERSAL MAST ANCHOR

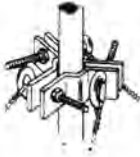

GUY WIRE CLAMP

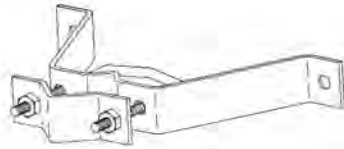

4" WALL MOUNT BRACKET

Pulsar 10 Installation

The Pulsar 10 is mounted on a tube in horizontal position.

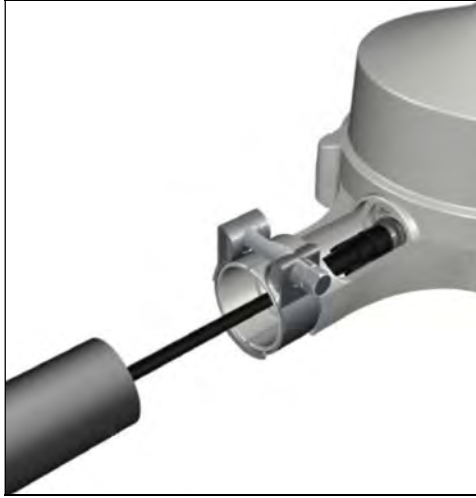

Follow the steps below to install the tube onto the sensor:

1. Feed the sensor cable through the provided tube
2. Attach the cable connector onto the connector of the sensor
3. Slide the tube through the bracket
4. Tighten the screw at the bracket
5. Using the provided hardware attach the tube horizontally to a vertical mast

SECTION 5: CALIBRATION & MAINTENANCE

Factory Calibration and Repair Service

Send the device to Columbia Weather Systems, Inc. for calibration and adjustment, see USER SUPPORT INFORMATION section for more information.

Cleaning

To ensure the accuracy of measurement results, the sensor transmitter should be cleaned when it becomes contaminated. Leaves and other such particles should be removed from the precipitation sensor and the transmitter should be cleaned carefully with a soft, lint-free cloth moistened with water.

SECTION 6: TROUBLESHOOTING

This chapter describes common problems, their probable causes and remedies.

Problem	Possible Cause	Action
Loss of communication with Pulsar sensor transmitter	Blown fuse Poor cable connection Surge protector tripped	Check the Interface Module fuse, replace if needed. Check all cable connections between sensor and optional monitoring device. By-pass surge protector to verify sensor functionality
Wind measurement failure. Both the speed and direction sensors are not reporting correct data	Blockage (trash, leaves, branches, debris) between the wind transducers. Confirm the wind transducers are not damaged.	Remove the blockage.

Loss of communication with Pulsar sensor transmitter:

- Check the Interface Module. If the Green Power LED and Red Power LED are out, it is possible that the fuse has blown. Disconnect power and remove the four screws on the front panel of the Interface Module to check the fuse.
- Check all weatherproof cable connectors between the Pulsar sensor and any optional monitoring device; e.g., MicroServer, Display Console. Look for broken or damaged pins. Also inspect the cable connectors for water intrusion.
- If a surge protector was purchased and installed, an electrical event may have tripped the protector. Test for loss of communication by bypassing the surge protector and establish a direct cable connection. Determine if communication has been reestablished. To purchase a replacement surge protector please call 1-503-629-0887 and reference Part No. 8355.

SECTION 7: USER SUPPORT INFORMATION

This section consists of the following items:

1. **One-Year Limited Warranty:** Please read this document carefully.
2. **Return for Repair Procedure:** This procedure is for your convenience in the event you must return your Pulsar for repair or replacement. Follow the packing instructions carefully to protect your instrument in transit.

Limited Warranty

Columbia Weather Systems, Inc. (CWS), warrants the Pulsar Weather Station to be free from defects in materials and/or workmanship when operated in accordance with the manufacturer's operating instructions, for one (1) years from date of purchase, subject to the provisions contained herein. CWS warranty shall extend to the original purchaser only and shall be limited to factory repair or replacement of defective parts.

EXCLUSIONS

Certain parts are not manufactured by CWS (i.e., certain purchased options, etc.) and are therefore not covered by this warranty. These parts may be covered by warranties issued by their respective manufacturers and although CWS will not warrant these parts, CWS will act as agent for the administration of any such independent warranties during the term of this warranty. This warranty does not cover normal maintenance, damage resulting from improper use or repair, or abuse by the operator. Damage caused by lightning or other electrical discharge is specifically excluded. This warranty extends only to repair or replacement, and shall in no event extend to consequential damages. In the event of operator repair or replacement, this warranty shall cover neither the advisability of the repair undertaken, nor the sufficiency of the repair itself.

THIS DOCUMENT REFLECTS THE ENTIRE AND EXCLUSIVE UNDERSTANDING OF THE PARTIES, AND EXCEPT AS OTHERWISE PROVIDED HEREIN, ALL OTHER WARRANTIES, EXPRESS OR IMPLIED, PARTICULARLY THE WARRANTIES OF MERCHANT ABILITY AND/OR FITNESS FOR A PARTICULAR PURPOSE ARE EXCLUDED.

This warranty gives you specific legal rights, and you may also have other rights which vary from state to state.

Return for Repair Procedure

1. In the event of defects or damage to your unit, first call the Service Department Monday through Friday, 8:30 am to 4:00 pm PST, (503) 629-0887 to determine the advisability of factory repair. The Service Department will issue an RMA number (Return Merchandise Authorization) to help us identify the package when received. Please write that number on the outside of the box.
2. In the event factory service is required, return your Pulsar Weather Station as follows:
 - A. Packing
 - ◆ Wrap the Sensor Transmitter in a plastic bag first.
 - ◆ Pack in original shipping carton or a sturdy oversized carton.
 - ◆ Use plenty of packing material.
 - B. Include:
 - ◆ A brief description of the problem with all known symptoms.
 - ◆ Your telephone number.
 - ◆ Your return street shipping address (UPS will not deliver to a P.O. box).
 - ◆ Write the RMA number on the outside of the box.
 - C. Shipping
 - ◆ Send freight prepaid (UPS recommended).
 - ◆ Insurance is recommended. (The factory can provide the current replacement value of the item being shipped for insurance purposes.)
 - D. Send to:

Columbia Weather Systems, Inc.
5285 NE Elam Young Parkway, Suite C100
Hillsboro, Oregon 97124
 - E. C.O.D. shipments will not be accepted.

3. If your unit is under warranty, after repair or replacement has been completed, it will be returned by a carrier and method chosen by Columbia Weather, Inc. to any destination within the continental U.S.A. If you desire some other specific form of conveyance or if you are located beyond these borders, then you must bear the additional cost of return shipment.
4. If your unit is not under warranty, we will call you with an estimate of the charges. If approved, your repaired unit will be returned after all charges, including parts, labor and return shipping and handling, have been paid. If not approved, your unit will be returned as is via UPS COD for the amount of the UPS COD freight charges.

Reference

Glossary

Aspirating Radiation Shield

A device used to shield a sensor such as a temperature probe from direct and indirect radiation and rain while providing access for ventilation.

Barometric Pressure

The pressure exerted by the atmosphere as a consequence of gravitational attraction exerted upon the "column" of air lying directly above the point in question.

Celsius Temperature Scale

A temperature scale with the ice point at 0 degrees and the boiling point of water at 100 degrees.

Dew Point

The temperature to which a given parcel of air must be cooled at constant pressure and constant water-vapor content in order for saturation to occur. When this temperature is below 0°C, it is sometimes called the frost point.

Density Altitude

Density altitude is a meteorological variable that is important to pilots, especially during the summer. The density altitude is the altitude in a standard atmosphere where the density is the same as the given atmospheric density. During a hot muggy summer day, a pilot begins take off from an airport with an elevation of 2,500 foot. Because of the warm temperature and the moisture in the air, the airplane has to work as if it was taking off at an airport at an elevation of 6000 feet resulting in the plane needing more power and a longer roll down the runway to take off.

Fahrenheit Temperature Scale

A temperature scale with the ice point at 32 degrees and the boiling point of water at 212 degrees.

Global Radiation

The total of direct solar radiation and diffused sky radiation received by a unit horizontal surface. Global radiation is measured by a Pyranometer.

Heat Index

The heat index or apparent temperature is a measure of discomfort due to the combination of heat and high humidity. It was developed in 1979 and is based on studies of evaporative skin cooling for combinations of temperature and humidity.

Precipitation Type

Precipitation Type is displayed as a code in the Weather MicroServer. Please reference the chart below to decipher the code.

Precipitation Type	Code
No precipitation	0
Unspecified precipitation	40
Liquid precipitation; rain	60
Solid precipitation; snow	70
Freezing Rain	67 (Pulsar 100 only)
Sleet	69 (Pulsar 100 only)
Hail	90 (Pulsar 100 only)

Pyranometer

It measures the combined intensity of incoming direct solar radiation and diffused sky radiation. The Pyranometer consists of a radiation-sensing element, which is mounted so that it views the entire sky.

Relative Humidity

Popularly called humidity. The ratio of the actual vapor pressure of the air to the saturation vapor pressure.

Sea Level Pressure

The atmospheric pressure at mean sea level, either directly measured or, most commonly, empirically determined from the observed station pressure.

In regions where the earth's surface pressure is above sea level, it is standard observational practice to reduce the observed surface pressure to the value that would exist at a point at sea level directly below.

Solar Radiation

The total electromagnetic radiation emitted by the sun. 99% of the sun's energy output falls within the wavelength interval from 0.15 microns to 4.0 microns, with peak intensity near 0.47 microns. About one-half of the total energy in the solar beam is contained within the visible spectrum from 0.4 to 0.7 microns, and most of the other half lies near infrared, a small additional portion lying in the ultraviolet.

Wind Chill

That part of the total cooling of a body caused by air motion.

Unit Conversion

Speed

Kilometers per hour = 1.610 x miles per hour

Knots = 0.869 x miles per hour

Meters per second = 0.448 x miles per hour

Feet per second = 1.467 x miles per hour

Temperature

Temperature in °C = $5/9$ (temperature in °F - 32)

Temperature in °F = (1.8 x temperature in °C) + 32

Distance

Millimeters = 25.4 x inches

Pressure

Millibars = 33.86 x inches of mercury

Kilopascals = 3.386 x inches of mercury

Pounds per square inch = 0.49 x inches of mercury

Standard atmospheres = 0.0334 x inches of mercury

Tables and Formulas

Wind Chill Chart

In 2001, NWS implemented an updated Wind chill Temperature (WCT) index. The change improves upon the former WCT Index used by the NWS and the Meteorological Services of Canada, which was based on the 1945 Siple and Passel Index.

In the fall of 2000, the Office of the Federal Coordinator for Meteorological Services and Supporting Research (OFCM) formed a group consisting of several Federal agencies, MSC, the academic community (Indiana University-Purdue University in Indianapolis (IUPUI), University of Delaware and University of Missouri), and the International Society of Biometeorology to evaluate and improve the wind chill formula. The group, chaired by the NWS, is called the Joint Action Group for temperature Indices (JAG/TI). JAG/TI's goal is to upgrade and standardize the index for temperature extremes internationally (e.g. Wind chill Index).

The current formula uses advances in science, technology, and computer modeling to provide a more accurate, understandable, and useful formula for calculating the dangers from winter winds and freezing temperatures.

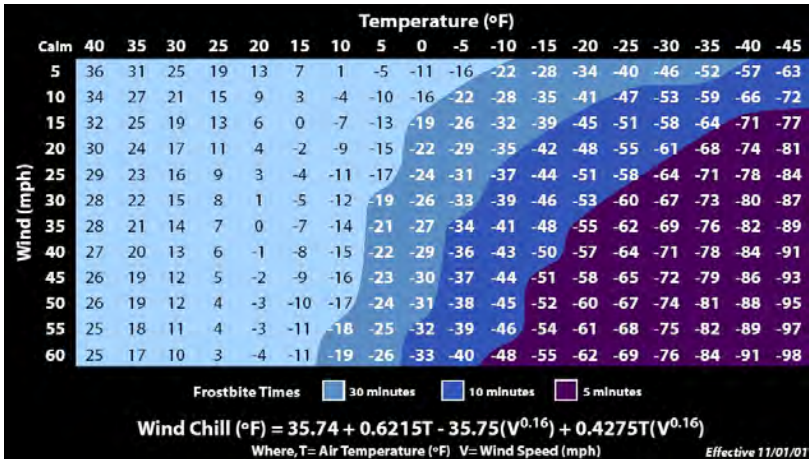

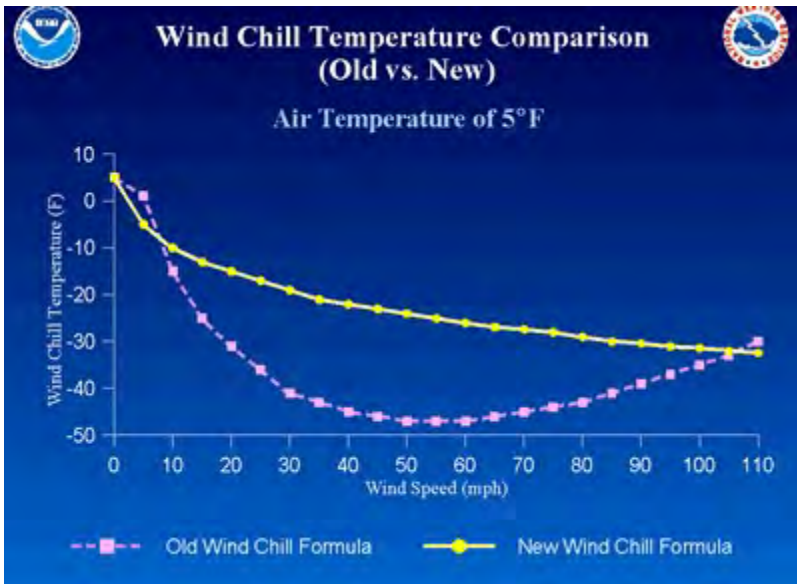

Wind Chill Equation

$$WC = 35.74 + 0.6215 T - 35.75(V^{0.16}) + 0.4275 T(V^{0.16})$$

Where:

WC = wind chill temperature in °F

V = wind velocity in mph

T = air temperature in °F

Note: Wind chill Temperature is only defined for temperatures at or below 50 degrees F and wind speeds above 3 mph.

Heat Index

RH	Temperature in °F													
	70	75	80	85	90	95	100	105	110	115	120	125	130	135
0	64	66	73	78	83	87	91	95	99	103	107	111	117	120
5	64	69	74	79	84	88	93	97	102	107	111	116	122	126
10	65	70	75	80	85	90	95	100	105	111	116	123	131	
15	65	71	76	81	86	91	97	102	108	115	123	131		
20	66	72	77	82	87	93	99	105	112	120	130	141		
25	66	72	77	83	88	94	101	109	117	127	139			
30	67	73	78	84	90	96	104	113	123	135	148			
35	67	73	79	85	91	98	107	118	130	143				
40	68	74	79	86	93	101	110	123	137	151				
45	68	74	80	87	95	104	115	129	143					
50	69	75	81	88	96	107	120	135	150					
55	69	75	81	89	98	110	126	142						
60	70	76	82	90	100	114	132	149						
65	70	76	83	91	102	119	138							
70	70	77	84	93	106	124	144							
75	70	77	85	95	109	130	150							
80	71	78	86	97	113	136								
85	71	78	87	99	117	140								
90	71	79	88	102	122	150								
95	71	79	89	105	126									
100	72	80	90	108	131									

Dew Point

$$B = (\ln (RH/100) + ((17.2694*T) / (238.3+T))) / 17.2694$$

$$\text{Dew Point in } ^\circ\text{C} = (238.3 * B) / (1-B)$$

Where:

RH = Relative Humidity

T = Temperature in $^\circ\text{C}$

Ln = Natural logarithm



Columbia Weather Systems, Inc.
5285 NE Elam Young Parkway, Suite C100
Hillsboro, OR 97124

Telephone

(503) 629-0887

Fax

(503) 629-0898

Web Site

<http://www.columbiaweather.com>

Email

support@columbiaweather.com

Part Number: 81659

Version 1.18

Printed in U.S.A.