



Columbia Weather Systems, Inc.
5285 N.E. Elam Young Parkway, C100
Hillsboro, Oregon 97124

Phone: (503) 629-0887
Fax: (503) 629-0898

www.columbiaweather.com

Ultrasonic Snow Depth/Water Level Sensor

Part Number - 82305 (IRU-6429-C6)

Rev F: 1/30/2024 (Mark 3)



The Ultrasonic Snow Depth/Water Level Sensor transmits an ultrasonic pulsed sound wave through the air to meet a reflective object, such as snow. When the sound wave contacts the target, it bounces back toward the sensor. The sensor records the time required for the sound wave to travel to the target and return. Using the speed of sound, the sensor calculates the distance to the object.

Technical Specifications:

Operating Conditions

1 to 30 ft. (0.3 to 9.1 m)

Operating Temp: -20° to +140°F (-30° to +60°C)

Electrical

Beam Pattern: 9° off axis

Frequency: 69 kHz

Accuracy: $\pm 0.25\%$ of detected range

Resolution: 0.1 in. (2.5 mm)

Power

Total Current Draw: 75 mA @ 24 VDC and 4 Hz

Supply Voltage: 12 to 28 VDC

Output: 0 to 2.5 VDC

Physical Dimensions



PVDF (Kynar®) transducer housing
PC/PET upper housing
Transducer Type: Ceramic, PVDF faced
IP65 Environmental Rating

Installation

Before operation can begin the sensor needs to be installed and calibrated under a clear area. Ideally calibration needs to be done before snow is on the ground.

The sensor is programmed to be mounted at a height of 18ft (216in) from the ground.

At 18ft (216in) the sensor requires a clear area of 68.4 inches in diameter (3.8" diameter clearance per foot).

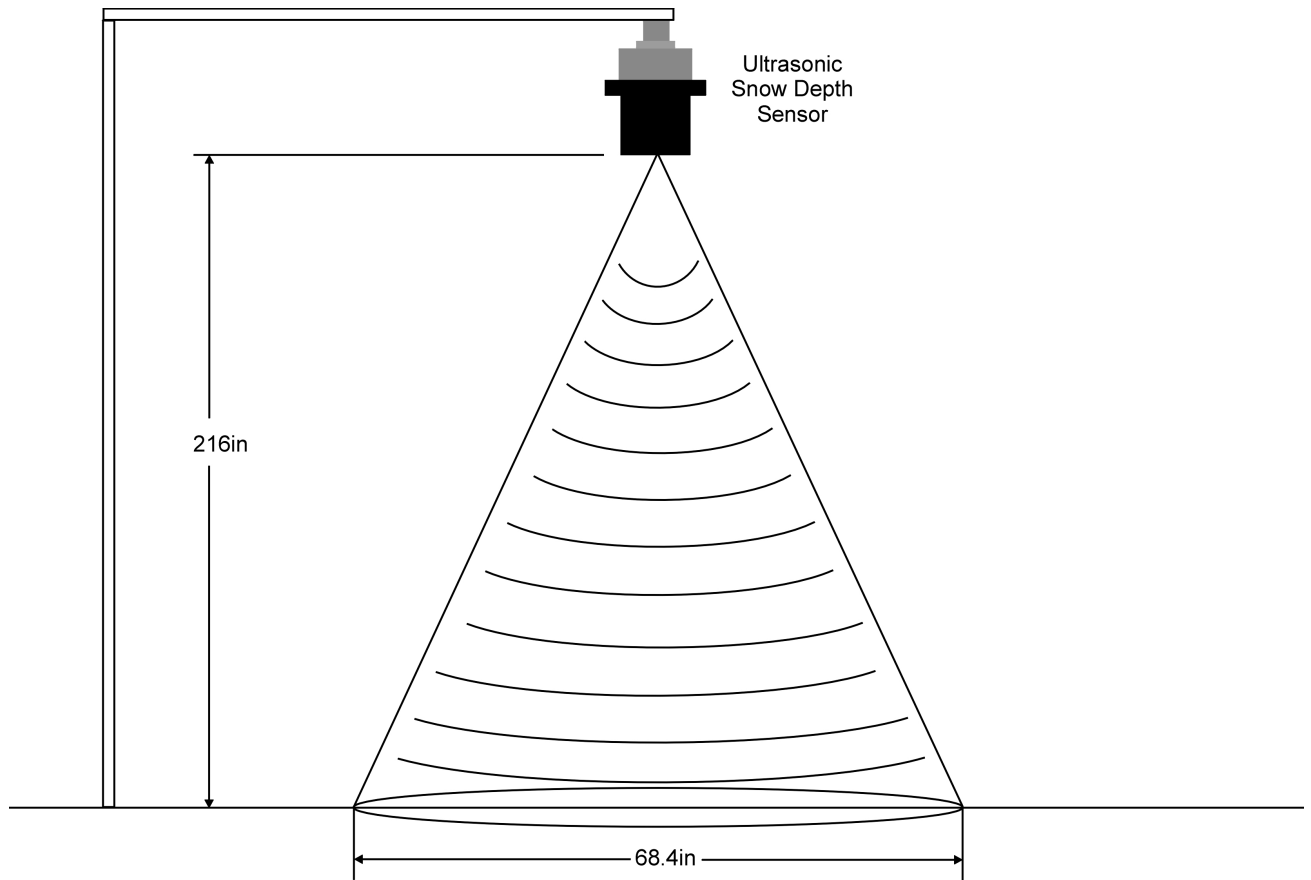

To avoid inaccurate readings the sensor should be mounted away from any obstructions in the measurement area.

If the sensor cannot be installed at 216in (18ft) an Offset will need to be entered into the Snow Depth offset on the Parameter Settings page.

Connection to the MicroServer

A 12VDC Power Supply is included to power the MicroServer.

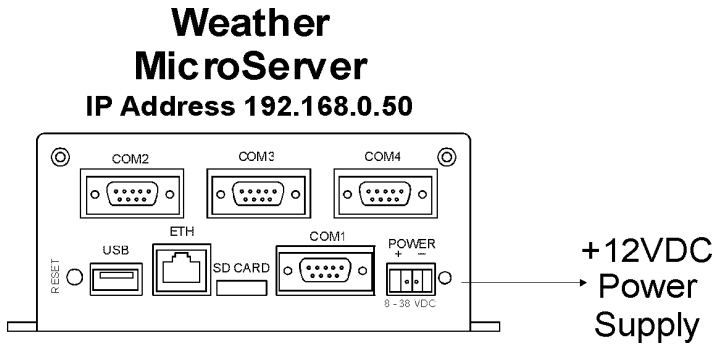

A separate 24VDC Power Supply is included to power the Snow Depth Sensor.

The Snow Depth Sensor connects to one of the analog Channels on the MicroServer.

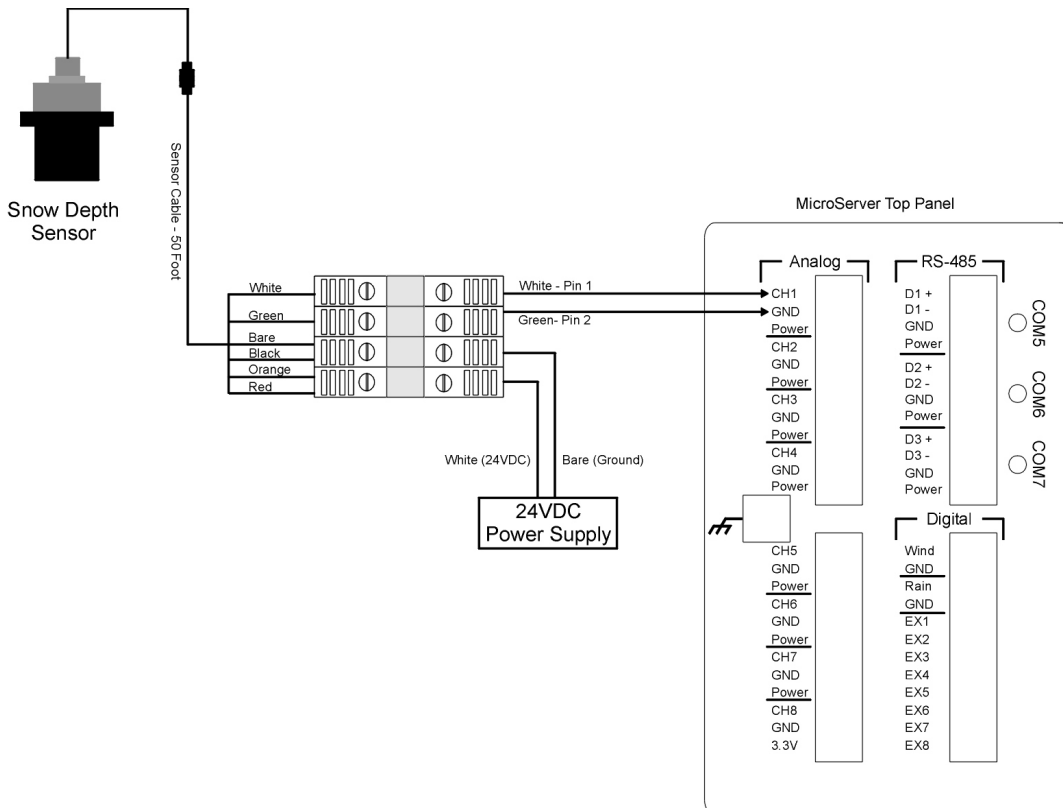

Configuration:

The MicroServer is provided preconfigured at the factory to work with the Snow Depth Sensor.

The following information is provided here for reference and calibration purposes.

On the Parameter Settings Page, the height of the Snow Depth Sensor is entered as an offset.

The default Snow Depth offset is 216.

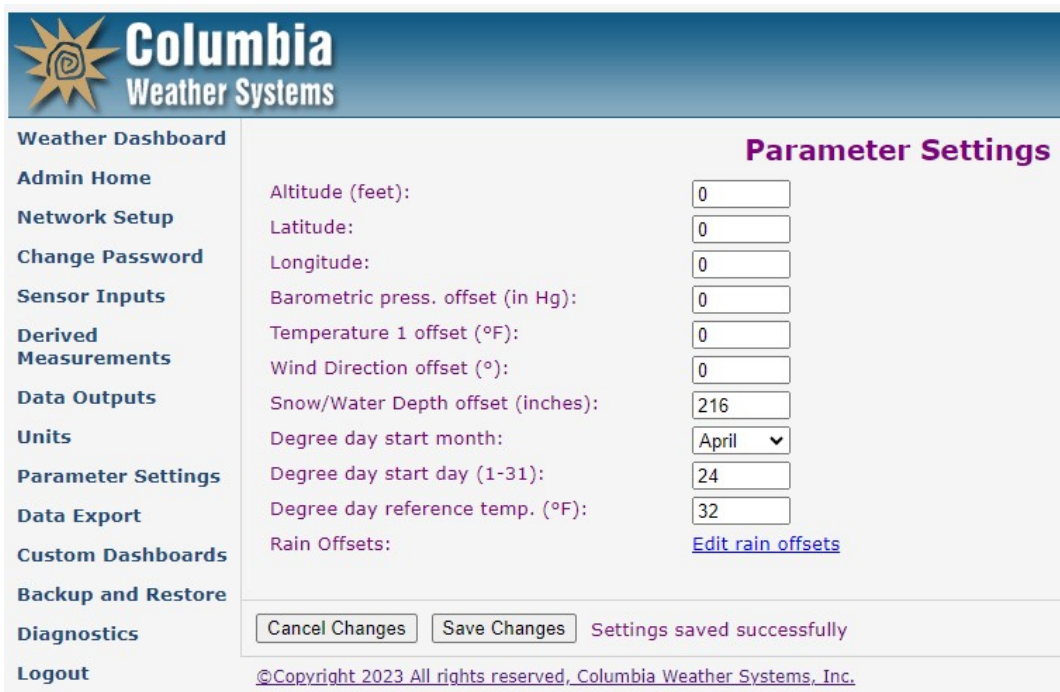

Columbia Weather Systems

Parameter Settings

Altitude (feet):	<input type="text" value="0"/>
Latitude:	<input type="text" value="0"/>
Longitude:	<input type="text" value="0"/>
Barometric press. offset (in Hg):	<input type="text" value="0"/>
Temperature 1 offset (°F):	<input type="text" value="0"/>
Wind Direction offset (°):	<input type="text" value="0"/>
Snow/Water Depth offset (inches):	<input type="text" value="216"/>
Degree day start month:	<input type="text" value="April"/>
Degree day start day (1-31):	<input type="text" value="24"/>
Degree day reference temp. (°F):	<input type="text" value="32"/>
Rain Offsets:	Edit rain offsets

Settings saved successfully

©Copyright 2023 All rights reserved, Columbia Weather Systems, Inc.

The sensor is programmed to be mounted at 216" (18ft) from the ground.

If the sensor height is different, enter the new height in inches into the Snow Depth offset on the Parameter Settings page as shown above.

On the Sensor Inputs page, a Custom Analog Sensor has been created with the following custom sensor settings:

Name: Snow Distance
Sensor Type: Snow Distance
Factor: - 86.4
Offset: 216

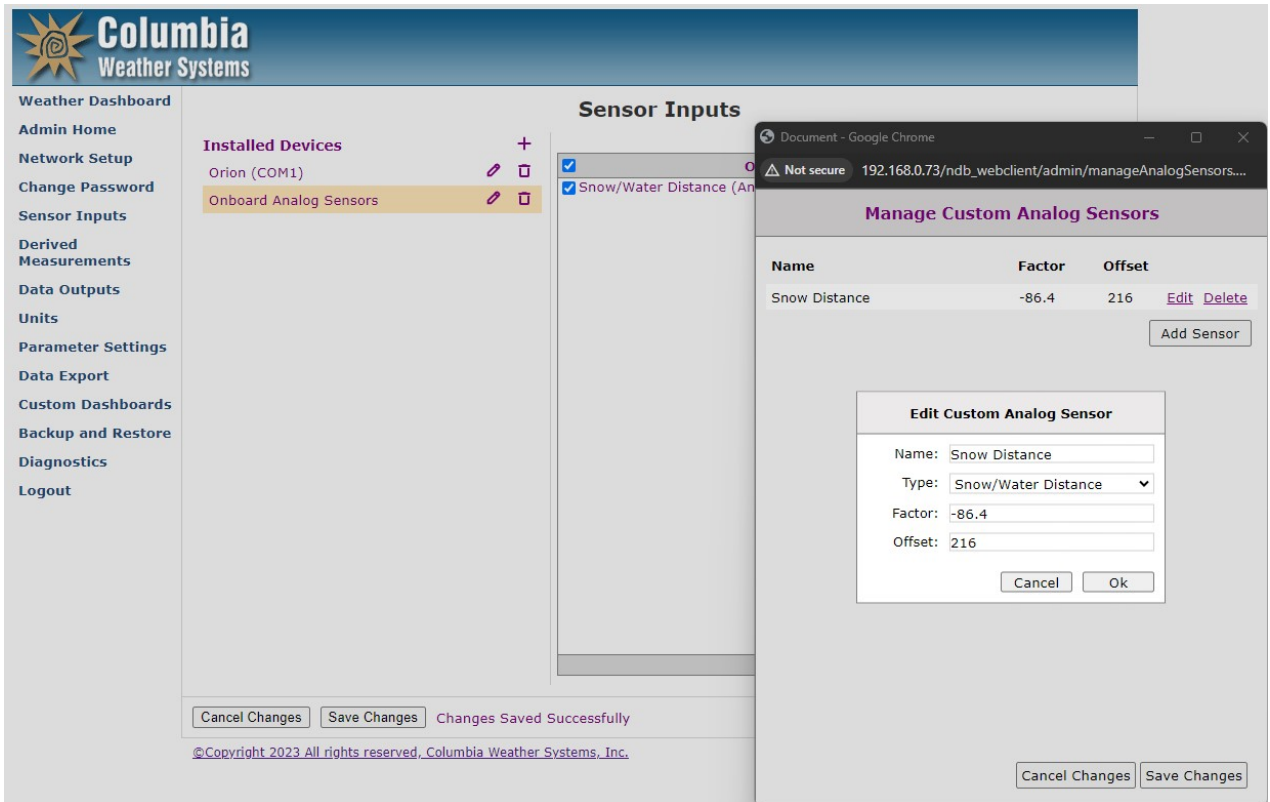

The Offset will vary from sensor to sensor due to calibration.

Calibration:

After the sensor is installed over clear ground and is connected to the MicroServer, the sensor Offset needs to be adjusted so that the sensor gives a zero reading.

To correctly calibrate the sensor, the ground below the sensor needs to be free of snow. If not, manually measure the snow depth in inches and calibrate for that value.

Please follow the procedure below to calibrate the sensor in the MicroServer:

1. Login to the MicroServer.
2. Click Latest Measurements.
3. Make note of the Snow Depth reading. If the reading is zero, then calibration is not required.
4. Click Data Inputs.
5. Under Custom Analog Sensors, next to the Snow Distance sensor click Edit.
6. Adjust the Offset. For example, if Snow Depth reading is 1 inch, then add 1 to the offset. If Snow Depth reading is -1, then subtract 1 from the offset.
7. Click OK then Apply Changes.
8. Click Latest Measurements to check the Snow Depth reading.
9. Continue to adjust the Offset until the Snow Depth reading is zero.

Note: Example above is in reference to Snow Depth however, the same procedure can be followed for Water Level.