

# Magellan 420 Weather Station™

## **User Manual**

Version 1.01

Serial Number: \_\_\_\_\_

Date Purchased: \_\_\_\_\_

All specifications subject to change without notice.

Printed in U. S. A.

© Copyright 2011 Columbia Weather Systems, Inc. All Rights Reserved.

Proprietary Notice: Magellan, Magellan 420, Orion, Orion 420, Orion LX, Capricorn 2000, Capricorn 2000MP and Capricorn 2000EX are trademarks of Columbia Weather Systems, Inc. The information and drawings contained herein are the sole property of Columbia Weather Systems, Inc. Use of this publication is reserved exclusively for customers of Columbia Weather Systems, Inc. and their personnel. Reproduction of this material is forbidden without the express written consent of Columbia Weather Systems, Inc.

---

# Welcome!

Congratulations on your purchase of a Magellan 420 Weather Station.

**Please read this manual completely prior to installation.**



# Important Notice: Shipping Damage

**BEFORE YOU READ ANY FURTHER, please inspect all system components for obvious shipping damage.** The Magellan is a high precision instrument and can be damaged by rough handling. Your unit was packaged to minimize the possibility of damage in transit. Please save the shipping container for any future shipment of your Magellan sensor.

In the event your order arrives in damaged condition, it is important that the following steps be taken immediately. The title transfers automatically to you, the customer, once the material is entrusted to the transport company.

**NOTE: DO NOT RETURN THE INSTRUMENT TO COLUMBIA WEATHER SYSTEMS** until the following steps are completed. Failure to follow this request will jeopardize your claim.

1. Open the container and inspect the contents. Do not throw away the container or any damaged parts. Try to keep items in the same condition as originally received.
2. Notify the transport company immediately.
3. Request the transport company's representative inspect the shipment personally.
4. After inspection, request a Return Materials Authorization (RMA) from Columbia Weather Systems by calling (503) 629-0887.
5. Return approved items to us at the following address:

**Columbia Weather Systems, Inc.**

**2240 NE Griffin Oaks Street, Suite 100**

**Hillsboro, OR 97124**

6. After a repair evaluation, an estimate of the cost of repair will be sent to you.

## ESD Protection

Electrostatic Discharge (ESD) can cause immediate or latent damage to electronic circuits. Vaisala products are adequately protected against ESD for their intended use. However, it is possible to damage the product by delivering electrostatic discharges when touching, removing, or inserting any objects inside the equipment housing.

To avoid delivering high static voltages yourself:

1. Handle ESD sensitive components on a properly grounded and protected ESD workbench. When this is not possible, ground yourself with a wrist strap and a resistive connection cord to the equipment chassis before touching the boards. When neither of the above is possible, at least touch a conductive part of the equipment chassis with your other hand before touching the boards.
2. Always hold the boards by the edges and avoid touching the component contacts.

# Table of Contents

<b>WELCOME! -----</b>	<b>3</b>
<b>IMPORTANT NOTICE: SHIPPING DAMAGE -----</b>	<b>5</b>
ESD PROTECTION.....	6
<b>SECTION 1: INTRODUCTION -----</b>	<b>9</b>
THE MAGELLAN 420 WEATHER STATION.....	9
SPECIFICATIONS.....	10
<i>Input Voltage</i> .....	10
<i>Sensor Housing</i> .....	11
<i>Serial to Analog Converters</i> .....	11
PRINCIPLES OF MEASUREMENTS.....	12
<i>Temperature</i> .....	12
<i>Humidity</i> .....	12
<i>Barometric Pressure</i> .....	12
<i>Wind Measurement</i> .....	12
<i>Fluxgate Compass</i> .....	12
<b>SECTION 2: PHYSICAL DESCRIPTION -----</b>	<b>13</b>
MAGELLAN SENSOR TRANSMITTER.....	13
MAGELLAN 420 ENCLOSURE.....	14
SURGE/LIGHTNING PROTECTORS.....	15
<b>SECTION 3: INSTALLATION -----</b>	<b>17</b>
WEATHER STATION SYSTEM CONFIGURATIONS.....	17
INSTALLATION OVERVIEW.....	18
UNPACKING THE UNIT.....	18
<i>Installing the Magellan Sensor Transmitter</i> .....	19
<i>Site Selection</i> .....	19
<i>North Alignment</i> .....	19
<i>Installing the Mast</i> .....	19
<i>Location</i> .....	19
<i>Mounting Method</i> .....	19
<i>Routing Cable</i> .....	20
<i>Location</i> .....	21
<i>Mounting Method</i> .....	21
<i>Routing Cable</i> .....	21
<i>Connecting the Sensor Transmitter to the Magellan 420 Enclosure</i> .....	22
<i>Connecting the 420 Enclosure to the PLC</i> .....	23
<b>SECTION 4: OPTIONAL SENSOR MOUNTING HARDWARE -----</b>	<b>25</b>

---

OPTIONAL SENSOR MOUNTING HARDWARE .....	25
<i>Tripod and Tiedown Kit</i> .....	25
<i>Specifications</i> .....	27
<i>Roof Mounting</i> .....	28
<i>Wall Mounting</i> .....	30
<b>SECTION 5: OPERATION -----</b>	<b>33</b>
<b>SECTION 6: MAINTENANCE -----</b>	<b>35</b>
FACTORY CALIBRATION AND REPAIR SERVICE .....	35
<b>SECTION 7: USER SUPPORT INFORMATION-----</b>	<b>37</b>
LIMITED WARRANTY .....	37
EXCLUSIONS .....	37
RETURN FOR REPAIR PROCEDURE .....	38



---

# SECTION 1: INTRODUCTION

## The Magellan 420 Weather Station

The Magellan 420 weather station provides wind direction and speed measurements, capacitive relative humidity, temperature and barometric pressure readings – all in a single sensor module.

The sensor transmitter includes a built-in electronics flux compass for automatic North orientation.

The Magellan 420 provides 4-20mA current output for the 6 weather parameters.

High accuracy and fine resolution make this system ideal for precision weather monitoring.

## Specifications

### Wind Speed

Range: 0-112mph (0-50 m/s)  
Accuracy: +/-0.5 m/s or 5% of reading  
Resolution: 1 mph (1 m/s)  
Units Available: knots, mph, km/hr, m/s

### Wind Direction

Azimuth: 0-360°  
Accuracy: ±5° at wind speed >2.2 m/s  
Resolution: 1°  
Units Available: ° Azimuth

### Temperature

Range: -58 to +122°F (-50 to +50°C)  
Accuracy: ±0.2°C  
Resolution: 0.1°C  
Units Available: °F, °C

### Barometric Pressure

Range: 17.50 to 32.50 InHg (600 to 1100 hPa)  
Accuracy: ±0.35 hPa (at 25°C)  
Resolution: 0.1 hPa  
Units Available: Kpa, mbar, InHg

### Relative Humidity

Range: 0 - 100%  
Accuracy: ±3%  
Resolution: 1%  
Units Available: %RH

### Compass

Accuracy: ±2°  
Resolution: 1°

### Input Voltage

The Magellan 420 is powered with an internal switching power supply  
Input: 120/240 VAC, 60 Hz

---

## **Sensor Housing**

Protection class: IP66 (with mounting adapter)

Materials: Polycarbonate + 20% glass fiber, stainless steel (AISI 316)

Weight: 650 g (1.43 lbs)

## **Serial to Analog Converters**

Analog Range: 4-20 mA

Current sourcing

Accuracy at 25°C: 0.1% of range

Maximum load: 600 ohms

Output reaction time: 0 – 40 ms

DA Conversion: 12 bits (resolution 4096)

Current Consumption: 30 mA to 110 mA

# Principles of Measurements

## Temperature

The temperature sensor in the Magellan uses a precision triple-element thermistor. This provides highly accurate and stable temperature readings.

## Humidity

The relative humidity sensor is a capacitive polymer sensor. The construction of the humidity sensor element provides excellent resistance to wetting, dust, dirt, oils, and common environmental chemicals.

## Barometric Pressure

The barometric pressure sensor is a stable transducer using nano-technology, yielding a linear and repeatable sensor with low hysteresis. The piezoresistive pressure sensor module is mounted on a small electronic circuit board.

A microcontroller controls the operation of the sensor and the data interface. The microcontroller polls the pressure sensor module once per second for the barometric pressure and ambient temperature. The raw readings are temperature corrected by the microcontroller.

## Wind Measurement

A unique folded-path, low-power sonic anemometer operates on the principle that the speed of the wind affects the time it takes for sound to travel from one point to a second point. If the sound is traveling in the direction of the wind, then the transit time is decreased. If the sound is traveling in a direction opposite the wind, then the transit time is increased.

## Fluxgate Compass

The internal compass module is low power and compact. It employs a pair of magneto-inductive sensors which change inductance with varying magnetic field strengths, to sense the Earth's magnetic field.

The microprocessor measures the output of the internal compass and then corrects wind direction data for the orientation of the sensor. The output of the wind direction is relative to magnetic North. A user programmable value of Magnetic Declination may be entered through terminal mode to enable output relative to True North rather than Magnetic North.

# SECTION 2: PHYSICAL DESCRIPTION

## Magellan Sensor Transmitter

The Magellan Sensor Transmitter is an all-in-one sensor unit containing sonic wind speed and direction sensor, temperature sensor, relative humidity sensor, and barometric pressure sensor.

The temperature and relative humidity sensors are combined in a single module housed in a self-aspirating radiation shield.

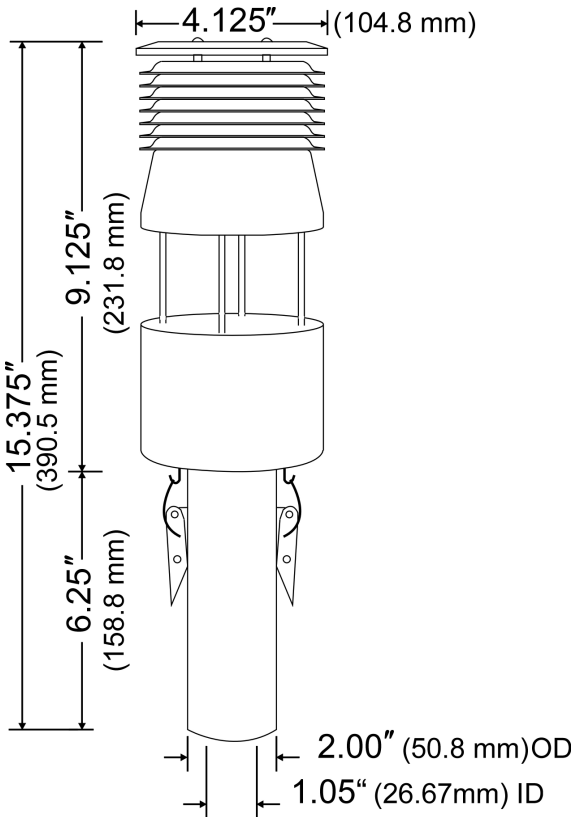

# Magellan 420 Enclosure



The Magellan 420 Enclosure contains the following:

1. AC power supply with +24 VDC output
2. AC power filter and suppressor
3. Two RS-232 to 4-20 mA converters
4. Sensor connection terminal block

The enclosure used is UL 508 Type 4, NEMA/EEMAC Type 4.

Enclosure flammability rating UL94-5V.

## Surge/Lightning Protectors



A nearby lightning strike may induce a high voltage surge which the internal suppressor of your weather instrument may not be able to withstand, causing significant damage to the weather station. Protect your weather station investment with the Magellan Surge Protector. This compact transient overvoltage suppressor is designed for weather stations in areas with an elevated risk of lightning strikes such as the top of high buildings, or installations with cable lengths greater than 100 feet.

- Superior 3-stage surge protection
- Tolerates up to 10kA surge currents
- Both differential and common mode protection on each channel
- Filtering against HF and RF noise
- Two power channels and two data channels
- Environmental protection class IP66

Catalog Number: 8355

Includes adjustable mounting kit





# SECTION 3: INSTALLATION

## Weather Station System Configurations

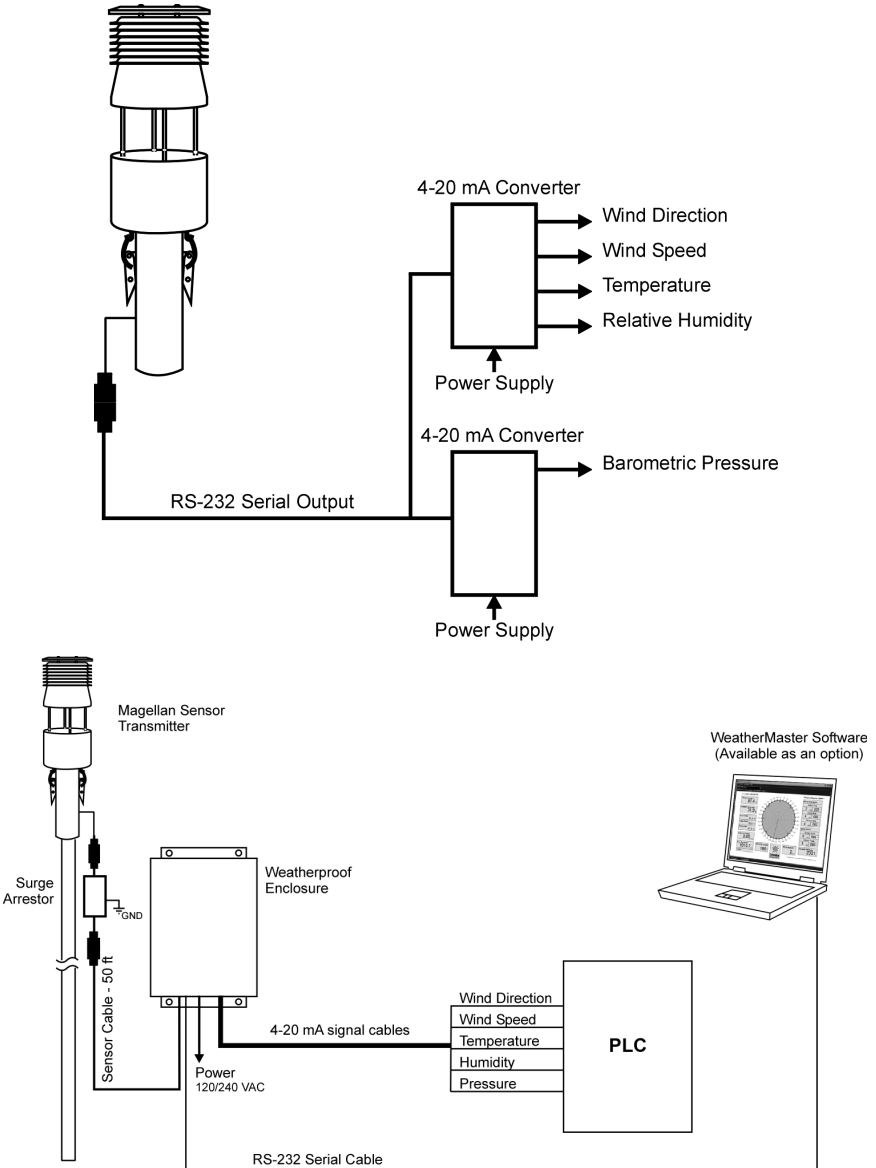

## Installation Overview

Unpacking the Unit

Installing Sensor Transmitter

Installing the Magellan 420 Weatherproof Enclosure

Connecting the Sensor Transmitter to the enclosure

Connecting the enclosure to the PLC

## Unpacking the Unit

The sensor transmitter comes in a custom shipping container. Be careful when removing the device.

Unpack the Magellan 420 weather station and verify that all parts are included.

1. Standard system includes:

- Magellan Sensor Transmitter
- 50 ft sensor cable + additional cable length if ordered
- Magellan 420 Weatherproof Enclosure
- User Manual

Inspect all system components for obvious shipping damage (Refer to “Important Notice: Shipping Damage” in case of damage).

Save the shipping carton and packing material in case the unit needs to be returned to the factory. If the system does not operate or calibrate properly, see Section 6: Maintenance and Section 7: Troubleshooting, for further instructions.

## Installing the Magellan Sensor Transmitter

### Site Selection

Finding a suitable site for the sensor transmitter is important for getting representative ambient measurements. The site should represent the general area of interest.

The sensor transmitter should be installed in a location that is free from turbulence caused by nearby objects, such as trees or buildings.

**WARNING:** To protect personnel (and the device), a lightning rod should be installed with the tip at least 40 inches (one meter) above the sensor transmitter. The rod must be properly grounded, compliant with all local applicable safety regulations.

### North Alignment

The Magellan sensor has a built-in electronic compass for North alignment.

The Magnetic Declination has been entered into the sensor for your area. To change the magnetic declination, please see the Operation section.

### Installing the Mast

There are three acceptable methods for mounting the mast to a roof or building structure: Sloped roof mounting, flat roof mounting or wall mounting. See **Optional Sensor Mounting Hardware** for more information.

### Location

Do not attach the sensor transmitter to a radio transmitting mast or tower.

Select a mounting location that will allow the sensor cable to be routed away from other data cables to avoid interference. Never route sensor cables in tall trees. Do not mount sensors close to power lines or telephone lines. For normal roof mounting, the recommended minimum distance from power or telephone lines is 25 ft. (8 m). Use extreme caution when working close to power lines.

### Mounting Method

Choose the appropriate mounting method for the installation and obtain any necessary mounting hardware. If the mounting hardware is not obtained from the factory, be certain to use metal parts which are plated or galvanized to assure maximum longevity.

Secure the mast to the roof, using guy wires with sufficient tensile strength or to building wall using a wall-mount hardware kit.

## Routing Cable

Use plastic tie wraps to secure the cable to mast, particularly at the mast base. Tighten the tie wraps securely and clip off any excess length with a wire cutter tool.

Route the cable back to the Interface Module

**CAUTION:** There may be electric wires in the wall. When routing cable through walls, we recommend that you shut off the electricity in the room(s) where you are drilling.

Any mast or tower should always be properly earth grounded to minimize electrical storm damage. The use of a properly grounded metal mast or tower, however, does not insure protection from electrostatic discharge. These items could become electrically charged resulting in damage to the sensors and/or console. This could damage the system in the event of an electrical storm. Use insulated standoffs (user supplied, see Section 4) when routing cable to help avoid this problem.

Note: If the standard 50 ft. cable provided with the sensor transmitter is not long enough, it may be extended by splicing on an appropriate length of 22-gauge, stranded, seven conductor shielded cable with the same color code. When cutting and splicing, insure good contacts, proper color coding of the terminal leads, and a good seal. (A good solder splice, and water proof insulation are essential; merely twisting the respective wires together is not adequate.) Additional cable (Catalog No. 81547) and a water tight splice kit (Cat. No. 81580) are available from the factory.

Once the sensor transmitter has been placed, route the cable back to the Interface Module.

## Location

Do not attach the sensor transmitter to a radio transmitting mast or tower.

Select a mounting location that will allow the sensor cable to be routed away from other data cables to avoid interference. Never route sensor cables in tall trees. Do not mount sensors close to power lines or telephone lines. For normal roof mounting, the recommended minimum distance from power or telephone lines is 25 ft. (8 m). Use extreme caution when working close to power lines.

## Mounting Method

Choose the appropriate mounting method for the installation and obtain any necessary mounting hardware. Refer to Section 4 for information on optional sensor mounting hardware and accessories which are available from the factory.

If the mounting hardware is not obtained from the factory, be certain to use metal parts which are plated or galvanized to assure maximum longevity.

Secure the mast to the roof, using guy wires with sufficient tensile strength or to building wall using a wall-mount hardware kit.

## Routing Cable

Use plastic tie wraps to secure the cable to mast, particularly at the mast base. Tighten the tie wraps securely and clip off any excess length with a wire cutter tool.

Route the cable back to the system enclosure.

**CAUTION:** There may be electric wires in the wall. When routing cable through walls, we recommend that you shut off the electricity in the room(s) where you are drilling.

Any mast or tower should always be properly earth grounded to minimize electrical storm damage. The use of a properly grounded metal mast or tower, however, does not insure protection from electrostatic discharge. These items could become electrically charged resulting in damage to the sensors. This could damage the system in the event of an electrical storm. Use insulated standoffs when routing cable to help avoid this problem.

Note: If the standard 50 ft. cable provided with the sensor transmitter is not long enough, it may be extended by splicing on an appropriate length of 22-gauge, stranded, seven conductor shielded cable with the same color code. When cutting and splicing, insure good contacts, proper color

coding of the terminal leads, and a good seal. (A good solder splice, and water proof insulation are essential; merely twisting the respective wires together is not adequate.) Additional cable (Catalog No. 81545) and a water tight splice kit (Cat. No. 81580) are available from the factory.

Once the sensor transmitter has been placed, route the cable back to the Magellan 420 enclosure.

## Connecting the Sensor Transmitter to the Magellan 420 Enclosure

Using a #1 Straight Slot screwdriver, attach the wires from the end of the sensor cable to the terminal block screws as shown below:

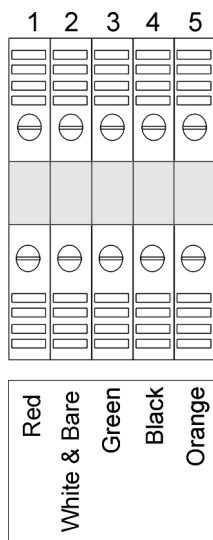

Sensor Cable

## Connecting the 420 Enclosure to the PLC

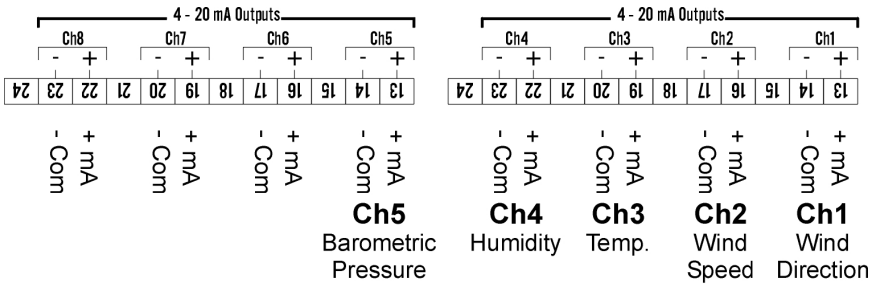

Ch1: Wind Direction Range: 0 to 360 degrees	Ch5: Barometric Pressure Range: 17 to 33 inches Hg
Ch2: Wind Speed Range: 0 to 135 mph	
Ch3: Temperature Range: -60 to +140 °F	
Ch4: Relative Humidity Range: 0 to 100%	





# Section 4: Optional Sensor Mounting Hardware

## Optional Sensor Mounting Hardware

### Tripod and Tiedown Kit

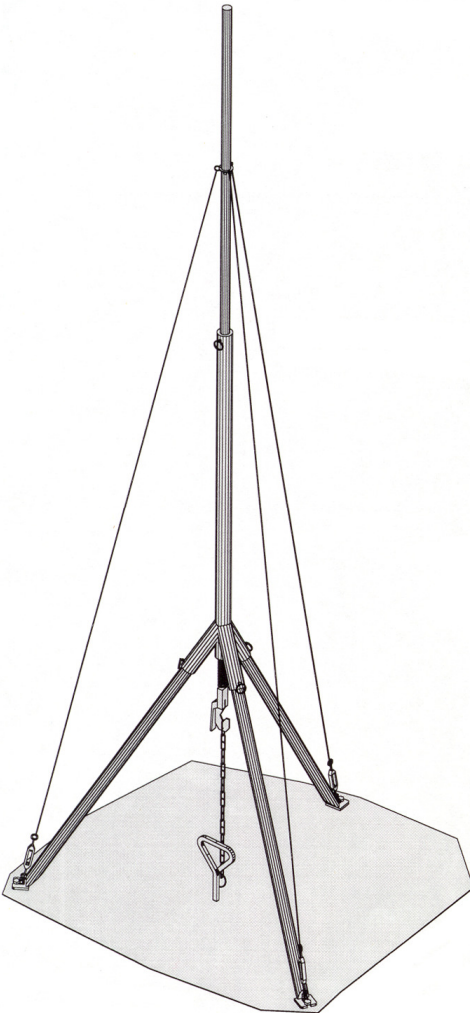

The meteorological tripod is designed to provide up to 10 feet of stable, secure support for your meteorological sensors.

Constructed from welded aluminum and powder coated for appearance and longevity, the 15-pound tripod can easily support up to 60 pounds of equipment. An optional tie-down kit allows for additional security in high-wind areas.

To install, insert the legs into the main body and secure with stainless steel retainer pins. Extend the mast to the desired height and insert another retainer pin. Install the guy wires to complete the set-up.

### Tripod Parts List:

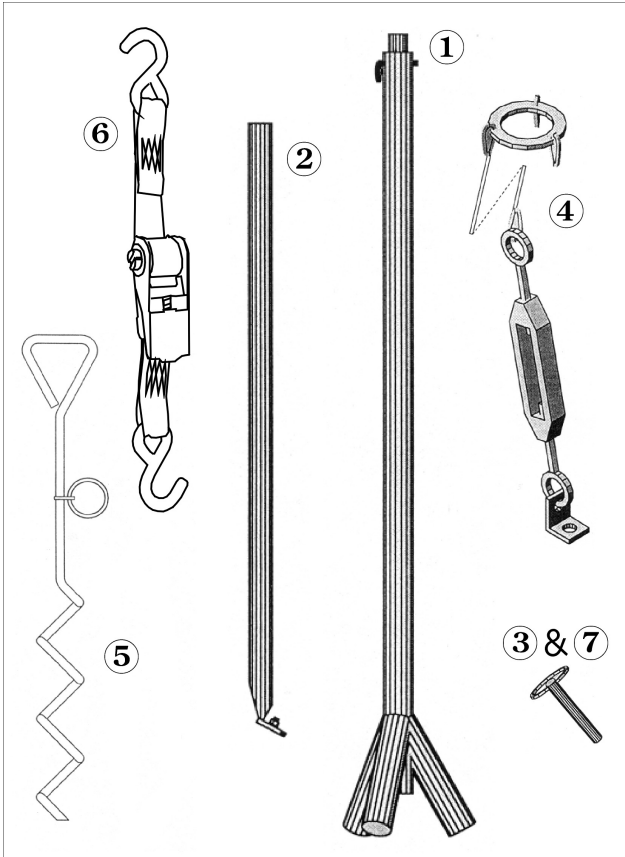

Item #	Description	Qty
1	Body/Mast Assembly	1
2	Legs	3
3	Retainer Pins	4
4	Guy Wire Ring with 3 Wires and Turnbuckles	1

---

5	Anchor Screw with Chain	1
6	Clamp with Strap	1
7	Retainer Pin	1

**Specifications**

Capacity: Supports up to 60 lbs.

Shipping Weight: 17 lbs

Shipping Box Dimensions: 70" x 8" x 8"

Tripod and Tiedown Kit Catalog Number: 88019

Fiberglass and steel 10-foot masts are available for use with either Roof Mounting Hardware Kit (Cat. No. 88002) or Wall Mounting Kit (Cat. No.88003).

## Roof Mounting

The Roof Mounting Kit (Cat. No. 88002) is suitable for both a slanted and flat roof installation. The figure and table below illustrates and describes the individual parts.

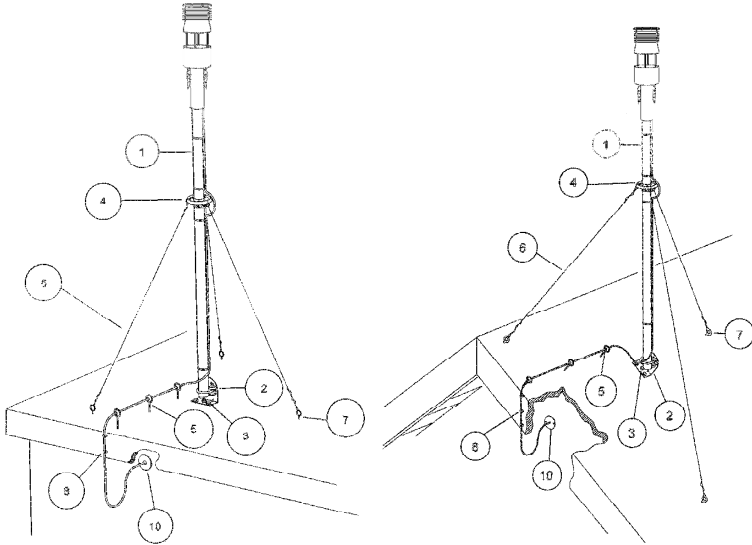

Description	Pkg.	Ref	Catalog No.
Mast, 10 ft. (steel or fiberglass)	1	1	88005 / 88004
Universal Mast Mount	1	2	88010
Lag Screw, Roof Mast Mount 1/4" x 2 1/4" (for comp. roofs)	4	3	88030
Cable Standoffs, Wood Screw	4	5	88050
Guy Wire Clamps, 1/8"	3	4	88070
Steel Guy Wire, Galvanized	50 ft.	6	88080
Eye Bolt Wood Screws, 1/4" x 3"	4	7	88090

---

Turnbuckles, 6" open x 4" closed	3	(not shown)	88100
Cable Nail Clips	20	8	88110
Cable Feed Through Bushings	4	10	88140

## Wall Mounting

The figure and table below illustrates and describes the individual parts in the Wall Mounting Kit (Catalog No. 88003). Items included in the kit are marked with an asterisk (\*). Individual parts are also available.

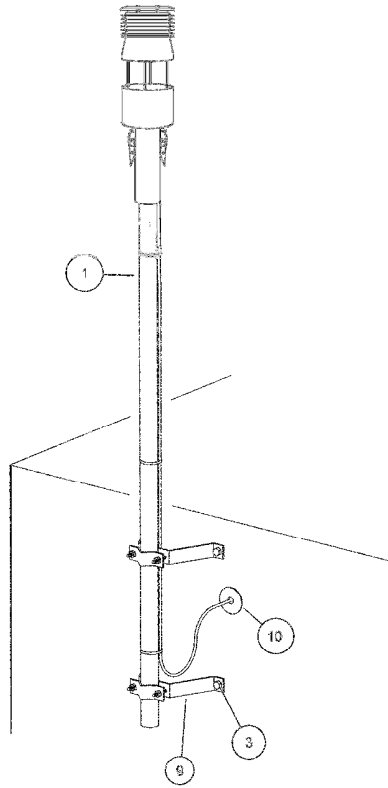

Description	Pkg.	Ref	Catalog No.
Mast, 10 ft.	1	1	88005
4" Wall Mount Bracket	2	9	88120
*Lag Screw, 1/4" x 2 1/4"	4	3	88030
Cable Nail Clips	20	8	88110
Cable Feed Through Bushings	4	10	88140

\* Not included in kit

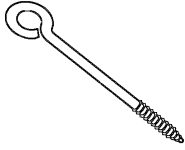

EYE BOLT SCREW

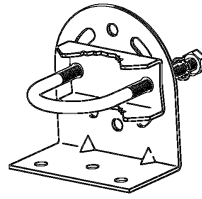

UNIVERSAL MAST MOUNT

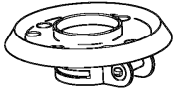

GUY RING & COLLAR

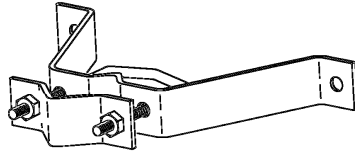

4" WALL MOUNT



CABLE NAIL CLIP

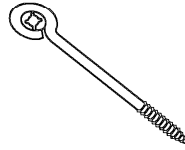

CABLE STANDOFF





---

# Section 5: Operation

The Magellan 420 outputs the following 8 parameters in 4-20 mA current signals:

## **Channel 1: Wind Direction**

Description: Instantaneous wind direction.

Range: 0 to 360 degrees

## **Channel 2: Wind Speed**

Description: Instantaneous wind speed.

Range: 0 to 135 mph

## **Channel 3: Temperature**

Description: Instantaneous temperature.

Range: -60 to +140 °F

## **Channel 4: Relative Humidity**

Description: Instantaneous relative humidity.

Range: 0 to 100%

## **Channel 5: Barometric Pressure**

Description: Instantaneous barometric pressure.

Range: 17 to 33 inches Hg.



## SECTION 6: MAINTENANCE

This chapter contains instructions for the basic maintenance of sensor transmitter.

Because the sensor has no moving parts to wear out, periodic maintenance is not required. In extremely corrosive environments, the condition of the connector used to mount the sensor should be checked. The only user repairable part is the Temperature/Relative Humidity Sensor Module (T/RH Module) located inside the removable multi-plate shield.

The T/RH Module is a single plug-in module with a keyed connector that assures correct electrical connection when the new unit is installed.

Replacement is accomplished easily with a Philips head screwdriver:

1. Remove the sensor module from the mounting adapter.
2. Remove the two screws from the top of the shield assembly.
3. Slide the top shield assembly off the support posts.
4. Unplug the existing T/RH Module.
5. Plug in the new or replacement T/RH Module noting that the connector will seat easily once the key is aligned.
6. Line up the shield assembly on the two support posts and slide it back into place.
7. Replace the two screws to secure the shield assembly.
8. Reconnect the sensor module to the mounting adapter.
9. The replacement is now complete.

### Factory Calibration and Repair Service

Send the device to Columbia Weather Systems, Inc. for calibration and adjustment, see Section 7: USER SUPPORT INFORMATION for more information.



# SECTION 7: USER SUPPORT INFORMATION

This section consists of the following items:

1. One-Year Limited Warranty: Please read this document carefully.
2. Return for Repair Procedure: This procedure is for your convenience in the event you must return your Magellan for repair or replacement. Follow the packing instructions carefully to protect your instrument in transit.

## Limited Warranty

Columbia Weather Systems, Inc. (CWS), warrants the Magellan Weather Station to be free from defects in materials and/or workmanship when operated in accordance with the manufacturer's operating instructions, for one (1) years from date of purchase, subject to the provisions contained herein. CWS warranty shall extend to the original purchaser only and shall be limited to factory repair or replacement of defective parts.

## EXCLUSIONS

Certain parts are not manufactured by CWS (i.e., certain purchased options, etc.) and are therefore not covered by this warranty. These parts may be covered by warranties issued by their respective manufacturers and although CWS will not warrant these parts, CWS will act as agent for the administration of any such independent warranties during the term of this warranty. This warranty does not cover normal maintenance, damage resulting from improper use or repair, or abuse by the operator. Damage caused by lightning or other electrical discharge is specifically excluded. This warranty extends only to repair or replacement, and shall in no event extend to consequential damages. In the event of operator repair or replacement, this warranty shall cover neither the advisability of the repair undertaken, nor the sufficiency of the repair itself.

THIS DOCUMENT REFLECTS THE ENTIRE AND EXCLUSIVE UNDERSTANDING OF THE PARTIES, AND EXCEPT AS OTHERWISE PROVIDED HEREIN, ALL OTHER WARRANTIES, EXPRESS OR IMPLIED, PARTICULARLY THE WARRANTIES OF MERCHANTABILITY AND/OR FITNESS FOR A PARTICULAR PURPOSE ARE EXCLUDED.

This warranty gives you specific legal rights, and you may also have other rights which vary from state to state.

## Return for Repair Procedure

1. In the event of defects or damage to your unit, first call the Service Department Monday through Friday, 8:30 am to 4:00 pm PST, (503) 629-0887 to determine the advisability of factory repair. The Service Department will issue an RMA number (Return Merchandise Authorization) to help us identify the package when received. Please write that number on the outside of the box.
2. In the event factory service is required, return your Magellan Weather Station as follows:
  - A. Packing
    - ◆ Wrap the Sensor Transmitter in a plastic bag first.
    - ◆ Pack in original shipping carton or a sturdy oversized carton.
    - ◆ Use plenty of packing material.
  - B. Include:
    - ◆ A brief description of the problem with all known symptoms.
    - ◆ Your telephone number.
    - ◆ Your return street shipping address (UPS will not deliver to a P.O. box).
    - ◆ Write the RMA number on the outside of the box.
  - C. Shipping
    - ◆ Send freight prepaid (UPS recommended).
    - ◆ Insurance is recommended. (The factory can provide the current replacement value of the item being shipped for insurance purposes.)

---

D. Send to:

Columbia Weather Systems, Inc.  
2240 NE Griffin Oaks Street, Suite 100  
Hillsboro, Oregon 97124

E. C.O.D. shipments will not be accepted.

3. If your unit is under warranty, after repair or replacement has been completed, it will be returned by a carrier and method chosen by Columbia Weather, Inc. to any destination within the continental U.S.A. If you desire some other specific form of conveyance or if you are located beyond these borders, then you must bear the additional cost of return shipment.
4. If your unit is not under warranty, we will call you with an estimate of the charges. If approved, your repaired unit will be returned after all charges, including parts, labor and return shipping and handling, have been paid. If not approved, your unit will be returned as is via UPS COD for the amount of the UPS COD freight charges.



Columbia Weather Systems, Inc.  
2240 NE Griffin Oaks Street, Suite 100  
Hillsboro, OR 97124-6463

**Telephone**

(503) 629-0887

**Fax**

(503) 629-0898

**Web Site**

<http://www.columbiaweather.com>

**Email**

[info@columbiaweather.com](mailto:info@columbiaweather.com)

Catalog Number: 81657

Version 1.01

Printed in U.S.A.