Vela Weather Station™

User Manual

Version 2.10

Serial Number: _____

Date Purchased: _____

All specifications subject to change without notice.

Printed in U. S. A.

© Copyright 2014 Columbia Weather Systems, Inc. All Rights Reserved.

Proprietary Notice: Vela, Orion, Capricorn 2000, Capricorn 2000EX, Capricorn FLX, Magellan and Pulsar are trademarks of Columbia Weather Systems, Inc. The information and drawings contained herein are the sole property of Columbia Weather Systems, Inc. Use of this publication is reserved exclusively for customers of Columbia Weather Systems, Inc. and their personnel. Reproduction of this material is forbidden without the express written consent of Columbia Weather Systems, Inc.

Welcome!

Congratulations on your purchase of a Vela Weather Station.

Please read this manual completely prior to installation.

Important Notice: Shipping Damage

BEFORE YOU READ ANY FURTHER, please inspect all system components for obvious shipping damage. The Vela is a high precision instrument and can be damaged by rough handling. Your unit was packaged to minimize the possibility of damage in transit. Please save the shipping container for any future shipment of your weather station.

In the event your order arrives in damaged condition, it is important that the following steps be taken immediately. The title transfers automatically to you, the customer, once the material is entrusted to the transport company.

NOTE: DO NOT RETURN THE INSTRUMENT TO COLUMBIA WEATHER SYSTEMS until the following steps are completed. Failure to follow this request will jeopardize your claim.

1. Open the container and inspect the contents. Do not throw away the container or any damaged parts. Try to keep items in the same condition as originally received.
2. Notify the transport company immediately.
3. Request the transport company's representative inspect the shipment personally.
4. After inspection, request a Return Materials Authorization (RMA) from Columbia Weather Systems by calling (503) 629-0887.
5. Return approved items to us at the following address:

Columbia Weather Systems, Inc.
2240 NE Griffin Oaks Street, Suite 100
Hillsboro, OR 97124

6. After a repair evaluation, an estimate of the cost of repair will be sent to you.

ESD Protection

Electrostatic Discharge (ESD) can cause immediate or latent damage to electronic circuits. The Weather Station is adequately protected against ESD for its intended use. However, it is possible to damage the product by delivering electrostatic discharges when touching, removing, or inserting any objects inside the equipment housing.

To avoid delivering high static voltages yourself:

1. Handle ESD sensitive components on a properly grounded and protected ESD workbench. When this is not possible, ground yourself with a wrist strap and a resistive connection cord to the equipment chassis before touching the boards. When neither of the above is possible, at least touch a conductive part of the equipment chassis with your other hand before touching the boards.
2. Always hold the boards by the edges and avoid touching the component contacts.

Table of Contents

WELCOME!	3
IMPORTANT NOTICE: SHIPPING DAMAGE	5
ESD PROTECTION	6
SECTION 1: INTRODUCTION	11
THE VELA WEATHER STATION	11
SPECIFICATIONS	12
<i>Operating Conditions</i>	12
<i>Wind Speed</i>	12
<i>Wind Direction</i>	12
<i>Relative Humidity</i>	12
<i>Temperature</i>	12
<i>Barometric Pressure</i>	13
<i>Precipitation (Optional Tipping Bucket Rain Gauge)</i>	13
<i>Input Voltage</i>	13
SECTION 2: PHYSICAL DESCRIPTION	15
VELA SENSOR TRANSMITTER	15
<i>Sensor Transmitter Components</i>	15
<i>Wind Speed and Wind Direction</i>	15
<i>Temperature and Humidity</i>	16
<i>Barometric Pressure</i>	16
<i>Rain Gauge (Optional)</i>	17
INTERFACE MODULE	18
SURGE/LIGHTNING PROTECTOR (OPTIONAL)	19
WEATHERMASTER™ SOFTWARE (OPTIONAL)	20
WEATHER DISPLAY CONSOLE (OPTIONAL)	21
WEATHER MICROSERVER (OPTIONAL)	22
SECTION 3: INSTALLATION	23
INSTALLATION OVERVIEW	23
UNPACKING THE UNIT	23
<i>Installing the Vela Sensor Transmitter</i>	24
<i>Site Selection</i>	24
<i>Direction alignment</i>	25
<i>Installing the Mast</i>	26
<i>Location</i>	26
<i>Mounting Method</i>	26
<i>Routing Cable</i>	26
<i>Connecting the Sensor Transmitter to the Interface Module</i>	28

OPTIONAL SENSOR MOUNTING HARDWARE.....	29
<i>Tripod and Tiedown Kit</i>	29
<i>Sensor Mast</i>	32
<i>Roof Mounting</i>	32
<i>Wall Mounting</i>	34
SECTION 4: OPTIONAL CONFIGURATIONS	37
SOLAR MONITORING SYSTEM	37
WIRELESS SYSTEM.....	38
VELA 420 PLC SYSTEM.....	39
VELA 420 ENCLOSURE	40
<i>Connecting the Vela Sensor Transmitter to the 420 Enclosure</i>	42
SECTION 5: REPLACING THE TEMPERATURE/HUMIDITY MODULE	43
SECTION 6: TROUBLESHOOTING	49
<i>Loss of communication with Vela sensor transmitter:</i>	49
SECTION 7: USER SUPPORT INFORMATION	51
LIMITED WARRANTY.....	51
EXCLUSIONS	51
RETURN FOR REPAIR PROCEDURE.....	53
REFERENCE	56
GLOSSARY	56
<i>Aspirating Radiation Shield</i>	56
<i>Barometric Pressure</i>	56
<i>Celsius Temperature Scale</i>	56
<i>Dew Point</i>	56
<i>Density Altitude</i>	56
<i>Fahrenheit Temperature Scale</i>	56
<i>Global Radiation</i>	57
<i>Heat Index</i>	57
<i>Pyranometer</i>	57
<i>Relative Humidity</i>	57
<i>Sea Level Pressure</i>	57
<i>Solar Radiation</i>	58
<i>Wind Chill</i>	58
UNIT CONVERSION	59
<i>Speed</i>	59
<i>Temperature</i>	59
<i>Distance</i>	59
<i>Pressure</i>	59
TABLES AND FORMULAS	60

<i>Wind Chill Chart</i>	60
<i>Wind Chill Equation</i>	61
<i>Heat Index</i>	62
<i>Dew Point</i>	63

SECTION 1: INTRODUCTION

The Vela Weather Station

The Vela Weather Station provides wind direction and speed measurements, relative humidity, temperature and barometric pressure readings – all in a single sensor module. A separate and optional tipping bucket rain gauge is available.

High accuracy and fine resolution make this system ideal for precision weather monitoring.

Vela weather data can be monitored with our proprietary Weather Display Console and WeatherMaster™ Software.

The Weather MicroServer is available for Ethernet connectivity, Modbus/TCP, Modbus RTU and SNMP interface, Weather Underground, Anything Weather and CWOP interface, XML weather data, and FTP.

Specifications

Operating Conditions

Temperature Operation: -40 to +60°C (-40 to +140°F)

Relative humidity: 0 to 100%

Pressure: 14.77 to 32.50 InHg (500 to 1100 hPa)

Wind: 0-112 mph (0 to 50 m/s)

Wind Speed

Range: 0-112 mph (0-50 m/s)

Accuracy: $\pm 2\%$

Starting Threshold: 1 m/sec

Resolution: 1 mph (1 m/s)

Units Available: knots, mph, km/hr, m/s

Wind Direction

Azimuth: 0-360°

Accuracy: $\pm 5^\circ$

Starting Threshold: 1 m/sec

Resolution: 1°

Units Available: ° Azimuth

Relative Humidity

Range: 0 - 100%

Accuracy: $\pm 4\%$

Resolution: 1%

Units Available: %RH

Temperature

Range: -60 to 140°F (-51 to +60°C)

Accuracy: $\pm 0.9^\circ\text{F}$ ($\pm 0.5^\circ\text{C}$)

Resolution: 0.1°F

Units Available: °F, °C

Barometric Pressure

Range: 14.77 to 32.50 InHg (500 to 1100 hPa)

Accuracy: ± 0.06 InHg (± 2 hPa) at 25 °C

Resolution: 0.01 InHg (0.1 hPa)

Units Available: Kpa, mbar, InHg

Precipitation (Optional Tipping Bucket Rain Gauge)

Range: cumulative

Collection diameter: 6 inches

Accuracy: $\pm 1\%$ at 2 inches/hour or less

Resolution 0.01 in. (0.254mm)

Units Available: mm, inches

Input Voltage

The Vela is supplied with a wall mount switching power supply

Input: 100 - 240 VAC, 50/60 HZ, 0.6A

Output: 12 VDC, 1.25A

The Vela can also be powered directly using a DC voltage source; MSO-232 model only.

Input: 8 to 36 VDC (10mA at 12 VDC).

SECTION 2: PHYSICAL DESCRIPTION

Vela Sensor Transmitter

The Vela sensor transmitter is an all-in-one sensor unit containing wind speed and direction sensor, temperature sensor, relative humidity sensor, and barometric pressure sensor.

The temperature and relative humidity sensors are combined in a single module housed in a self-aspirating radiation shield.

Sensor Transmitter Components



Wind Speed and Wind Direction

The Vela sensor transmitter uses a three cup anemometer, for accuracy, sensitivity, and durability. The cups are connected to a shaft, which turns a sensing element that converts the rotation into a series of electronic pluses.

A lightweight vane tail provides the motive power for the wind direction portion of the sensor. As the vane tail moves, it turns a shaft on a pair of bearings. That shaft turns a sensing element that converts the rotation into analog voltage.

Temperature and Humidity

Both Temperature and Humidity are built into the temperature shield at the bottom of the sensor. The integral shield limits errors due to solar radiation. The RH sensor is a capacitive element enclosed in a protective membrane.

Barometric Pressure

A solid state pressure sensor built into the sensor electronics provides accurate measurement of barometric pressure changes over a wide range. Electronic temperature compensation is included for highest accuracy over the operating temperature of the sensor.

Rain Gauge (Optional)



This optional tipping bucket rain gauge is composed of a complex spun collector funnel with a knife-edge that diverts the water to a tipping bucket mechanism. For each tip, a magnet causes an electronic pulse to be generated. The rainfall sensor is completely automatic - spent water drains out of the bottom of the housing; hence, the instrument requires no servicing. The rain gauge comes with a standard 50-foot cable and a quick disconnect connector pair.

Interface Module

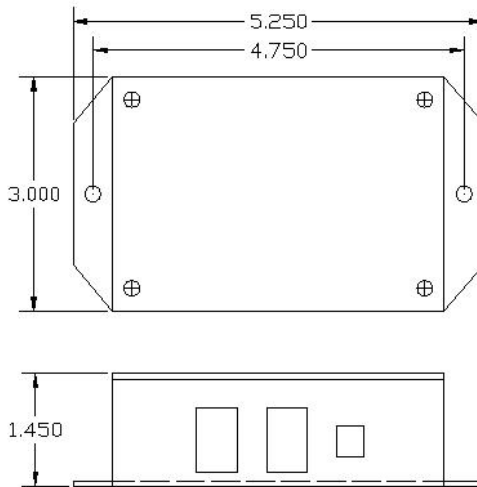

The Interface Module is used to supply power to the sensor transmitter and to provide two RS-232 communication ports. The RS-232 ports can be connected to computers, display consoles, transceivers, and other such devices.

The Interface Module has two LED indicators. The green LED is a power indicator and the red LED is a data indicator. In normal operation, the red LED will flash every second to indicate a data record being transmitted.

Surge/Lightning Protector (Optional)



A nearby lightning strike may induce a high voltage surge which the internal suppressor of your weather instrument may not be able to withstand, causing significant damage to the weather station. Protect your weather station investment with the Surge Protector. This compact transient overvoltage suppressor is designed for weather stations in areas with an elevated risk of lightning strikes such as the top of high buildings, or installations with cable lengths greater than 100 feet.

- Superior 3-stage surge protection
- Tolerates up to 10kA surge currents
- Both differential and common mode protection on each channel
- Filtering against HF and RF noise
- Two power channels and two data channels
- Environmental protection class IP66

Catalog Number: 8355

Includes adjustable mounting kit

WeatherMaster™ Software (Optional)

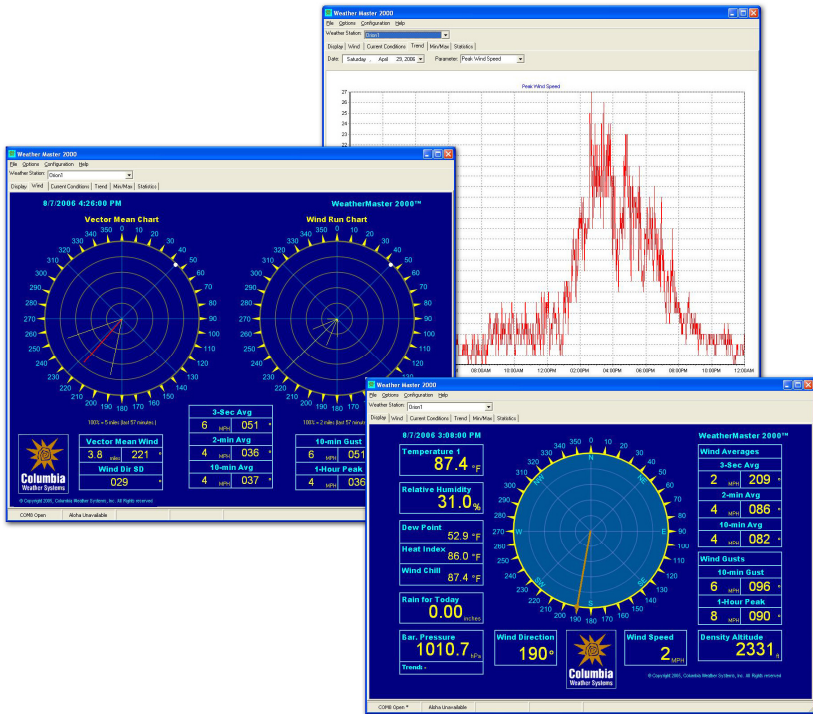

WeatherMaster is professional grade weather monitoring software. This software package is designed for specialized markets that require robust weather calculations, interoperability with computer models, and data interfaces to other industrial systems. WeatherMaster utilizes Microsoft Access database for easy data access and manipulation.

Please refer to the WeatherMaster user manual for installation and operation procedures

Weather Display Console (Optional)



Displays weather information • Designed to be viewed clearly from a distance • Industrial grade WVGA touchscreen.

Seven-inch, TFT color LCD panel with 800 x 480 pixel resolution.

Performs computations for wind chill, heat index and other calculated parameters • 200MHz ARM9 CPU

Serial or Ethernet connection: Connects directly to weather station with serial port or connects to a Weather MicroServer over a network utilizing an existing Ethernet infrastructure -- no extra wiring. The MicroServer configuration also allows for data from one weather station to be monitored from multiple display consoles at various locations.

Screens can be factory-customized to meet specialized market and industry requirements.

The Weather Display is also available in a 19" rack-mount chassis and a panel-mount configuration.

Please refer to the Weather Display Console user manual for more information.

Weather MicroServer (Optional)

The Weather MicroServer uses a small computer board that runs an embedded Linux operating system.

The MicroServer has 32MB flash memory for operation and 8 GB SD card for data logging.

The Vela transmitter connects to the MicroServer via COM1.

The MicroServer has three RS-232 COM ports and an Ethernet port.



The MicroServer offers the following:

- XML Weather Data
- FTP weather data in XML or CSV format
- Modbus/TCP, Modbus RTU (Serial RS-485), and Modbus ASCII interfaces
- SNMP interface
- Weather Underground & Anything Weather interface
- CWOP interface
- Three months of data logging at 1-minute interval
- Interface to optional visibility, solar radiation sensors, and temperature sensors

Please refer to the Weather MicroServer user manual for more information.

SECTION 3: INSTALLATION

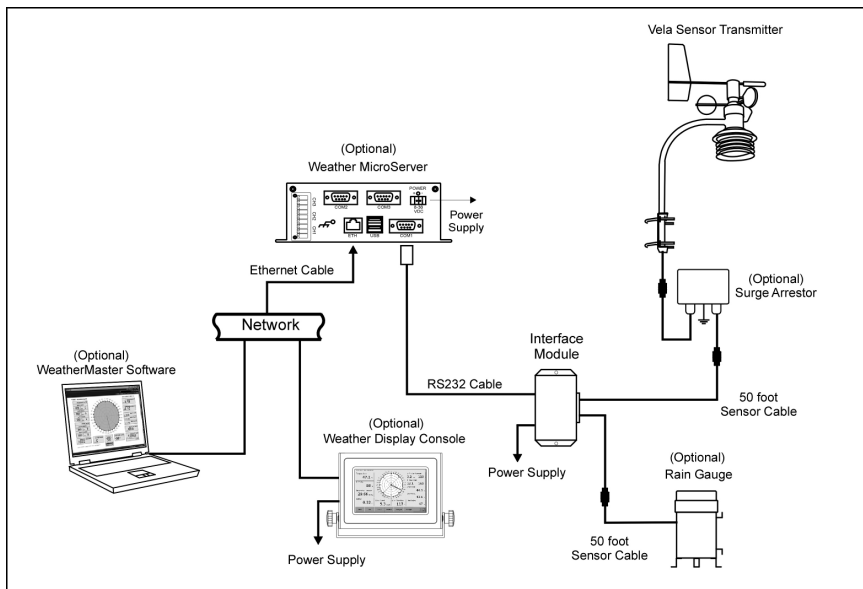

Installation Overview

Unpacking the Unit

Installing Sensor Transmitter

Installing the Interface Module

Connecting the Sensor Transmitter to the Interface Module

Connecting to MicroServer, Weather Display and Computer

Unpacking the Unit

The sensor transmitter comes in a custom shipping container. Be careful when removing the device.

Unpack the Vela weather station and verify that all parts are included.

1. Standard system includes:

- Vela Sensor Transmitter
- 50 ft sensor cable + additional cable length if ordered
- Interface Module
- (2) 3-position terminal blocks

- Interface module power supply
- User Manual
- 7-foot RS-232 cable + additional cable length if ordered

2. Weather Display Console (**Optional**)

- Display Console
- Power supply
- 6-foot RS-232 cable + additional cable length if ordered
- User manual

3. WeatherMaster software and user manual (**Optional**)

4. Weather MicroServer (**Optional**):

- MicroServer
- Power supply
- 7-foot Ethernet cable
- User manual

Inspect all system components for obvious shipping damage (Refer to “Important Notice: Shipping Damage” in case of damage).

NOTE: Save the shipping carton and packing material in case the unit needs to be returned to the factory. If the system does not operate properly, see the Troubleshooting section, for further instructions.

Installing the Vela Sensor Transmitter

Site Selection

Finding a suitable site for the sensor transmitter is important in obtaining representative ambient measurements. The site should represent the general area of interest.

The sensor transmitter should be installed in a location that is free from turbulence caused by nearby objects, such as trees or buildings.

To protect personnel (and the device), a lightning rod can be installed with the tip at least 40 inches (one meter) above the sensor transmitter. The rod must be properly grounded, compliant with all local applicable safety regulations.



Use quick mount U-bolts to install on vertical or horizontal mast, pole or pipe.

Tighten nuts, keeping sensor level.

Direction alignment

Install alignment shoulder screw into wind direction vane hub.

Align sensor so wind direction counterweight is to the South, vane tail is to true North.

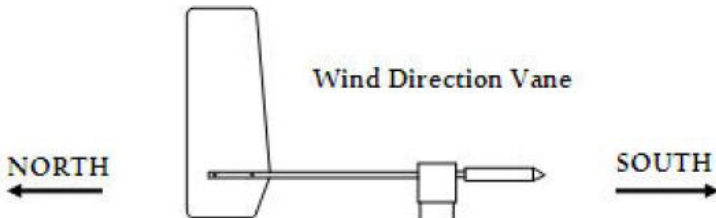

Installing the Mast

There are three acceptable methods for mounting the mast to a roof or building structure: Sloped roof mounting, flat roof mounting or wall mounting. See **Optional Sensor Mounting Hardware** for more information.

Any mast or tower should always be properly earth grounded to minimize electrical storm damage. The use of a properly grounded metal mast or tower, however, does not insure protection from electrostatic discharge. These items could become electrically charged resulting in damage to the sensors and/or console. This could damage the system in the event of an electrical storm.

Location

Do not attach the sensor transmitter to a radio transmitting mast or tower.

Select a mounting location that will allow the sensor cable to be routed away from other data cables to avoid interference. Never route sensor cables in tall trees. Do not mount sensors close to power lines or telephone lines. For normal roof mounting, the recommended minimum distance from power or telephone lines is 25 ft. (8 m). Use extreme caution when working close to power lines.

Mounting Method

Choose the appropriate mounting method for the installation and obtain any necessary mounting hardware. Refer to Optional Sensor Mounting Hardware section for information on mounting hardware and accessories which are available from the factory.

If the mounting hardware is not obtained from the factory, be certain to use metal parts which are plated or galvanized to assure maximum longevity.

Secure the mast to the roof, using guy wires with sufficient tensile strength or to building wall using a wall-mount hardware kit.

Routing Cable

Use plastic tie wraps to secure the cable to mast, particularly at the mast base. Tighten the tie wraps securely and clip off any excess length with a wire cutter tool.

Once the Vela sensor transmitter has been installed, route the cable back to the Interface Module.

CAUTION: There may be electrical wires in the wall. When routing cable through walls, we recommend that you shut off the electricity in the room(s) where you are drilling.

Note: If the standard 50 ft. cable provided with the sensor transmitter is not long enough, it may be extended by splicing on an appropriate length of 22-gauge, stranded, seven conductor shielded cable with the same color code. When cutting and splicing, insure good contacts, proper color coding of the terminal leads, and a good seal. (A good solder splice, and water proof insulation are essential; merely twisting the respective wires together is not adequate.) Additional cable (Part No. 81547) is available from the factory.

Connecting the Sensor Transmitter to the Interface Module

Using a #1 Straight Slot screwdriver, attach the wires from the end of the sensor cable to the terminal block screws on the Interface Module as follows:

Terminal Number	Function	Color
1	+12 V	Red
2	Ground	White & Bare
3	N/C	(Red)* & Blue
4	Signal Ground	Green, (Black & Bare)*
5	RX	Black
6	TX	Orange

*Rain Gauge cable

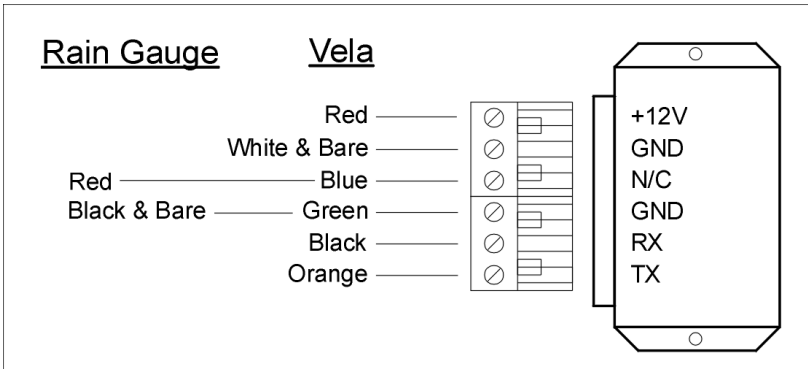

Optional Sensor Mounting Hardware

Tripod and Tiedown Kit

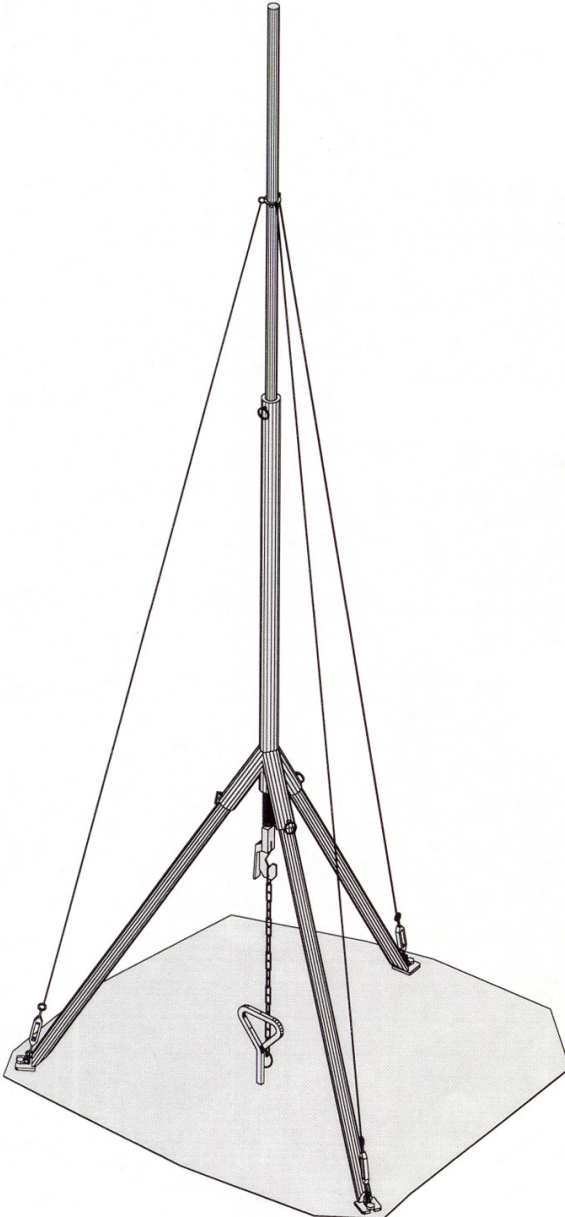

The meteorological tripod is designed to provide up to 10 feet of stable, secure support for your meteorological sensors.

Constructed from welded aluminum and powder coated for appearance and longevity, the 15-pound tripod can easily support up to 60 pounds of equipment. An optional tie-down kit allows for additional security in high-wind areas.

To install, place the guy wire collar on the mast before extending the mast, insert the legs into the main body and secure with stainless steel retainer pins. Extend the mast to the desired height and insert another retainer pin. Install the guy wires to complete the set-up.

Tripod Parts List:

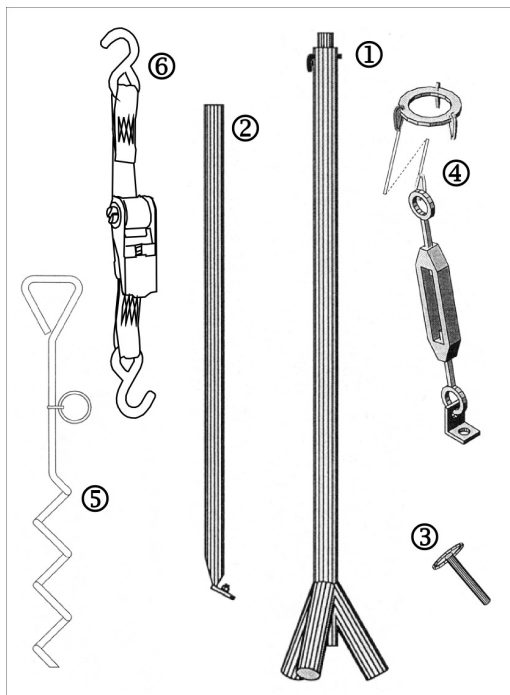

Item #	Description	Qty
1	Body/Mast Assembly	1
2	Legs	3
3	Retainer Pins	4
4	Guy Wire Ring with 3 Wires and Turnbuckles	1
5	Anchor Screw with Chain	1
6	Clamp with Strap	1
7	Retainer Pin	1

Specifications

Capacity: Supports up to 60 lbs.

Shipping Weight: 17 lbs

Shipping Box Dimensions: 71" x 9" x 9"

Tripod and Tiedown Kit Part Number: 88019

Sensor Mast

10-foot steel mast available for use with Roof Mount Hardware Kit (Part No. 88002) or Wall Mount Kit (Part No.88003).

Roof Mounting

The Roof Mount Kit (Part No. 88002) is suitable for both a slanted and flat roof installation. The figure and table below illustrates and describes the individual parts.

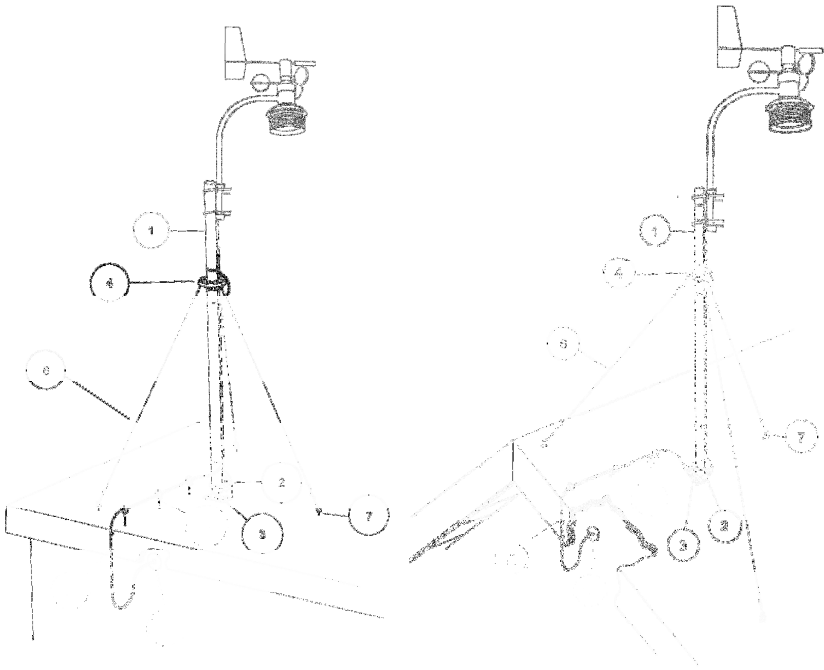

<u>Description</u>	<u>Ref.</u>	<u>Qty.</u>	<u>Part No.</u>
Steel mast, 10 ft.	1	1	88005
Universal Mast Anchor	2	1	88010
Lag Screw, Roof Mast Mount 1/4" x 2 1/4" (for comp. roofs)	3	4	88030
Guy Wire Clamp, 1/8"	4	1	88070
Steel Guy Wire, Galvanized	6	50ft.	88080
Eye Bolt Wood Screws, 1/4" x 3"	7	4	88090
Turnbuckles, 6" open x 4" closed (not shown)		3	88100

Wall Mounting

The figure and table below illustrates and describes the individual parts in the Wall Mount Kit (Part No. 88003). Individual parts are also available.

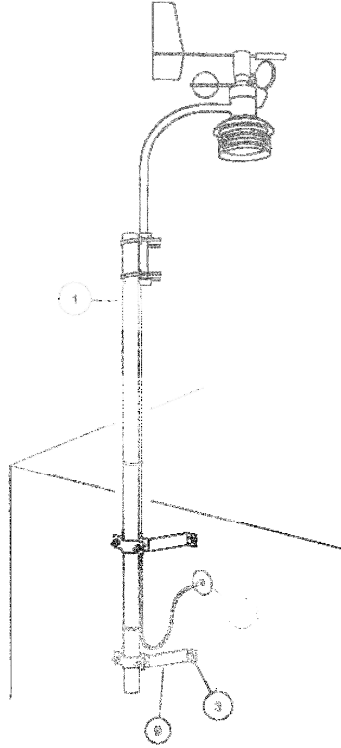

Description	Ref.	Qty.	Part No.
Mast, 10 ft.	1	1	88005
4" Wall Mount Bracket	9	2	88120
Lag Screw	3	4	88030

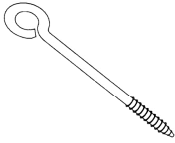

EYE BOLT SCREW

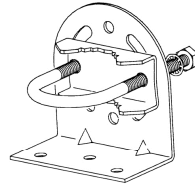

UNIVERSAL MAST ANCHOR

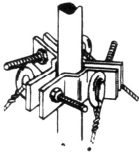

GUY WIRE CLAMP

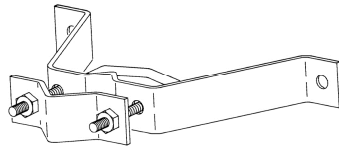

4" WALL MOUNT BRACKET

SECTION 4: OPTIONAL CONFIGURATIONS

Solar Monitoring System

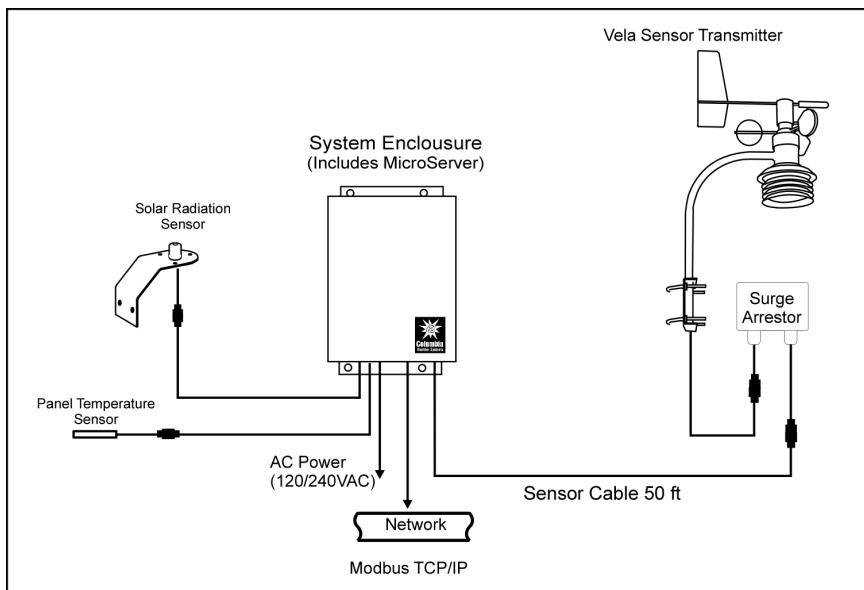

The Solar Monitoring System includes the Vela sensor transmitter, 8-Channel MicroServer, Panel Temperature Sensor and one or more Solar Radiation Sensors.

An optional tipping bucket rain gauge can also be connected to measure rainfall (not shown here).

The MicroServer is capable of Modbus TCP/IP over Ethernet and Modbus RTU (RS-485). Please refer to the MicroServer User Manual for more details.

Wireless System

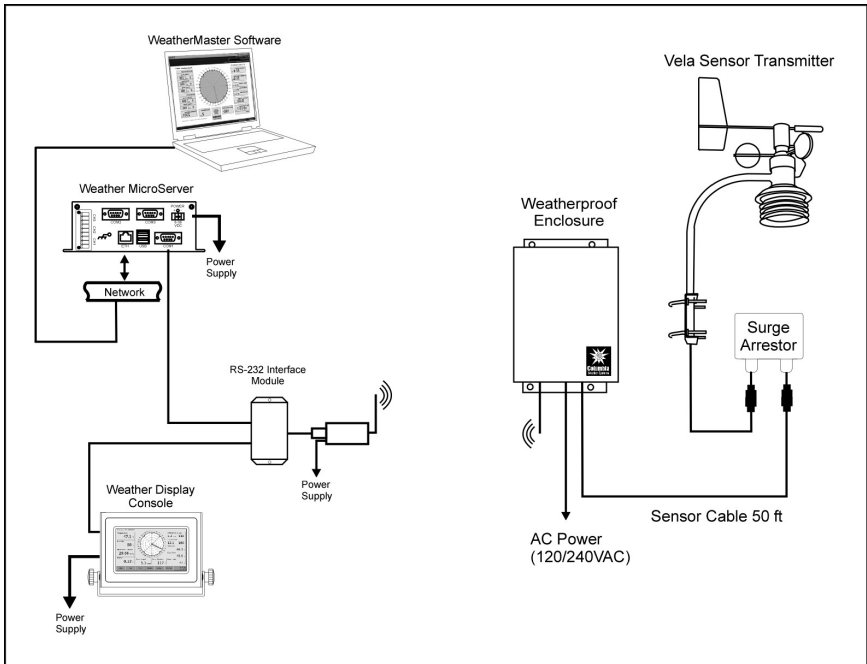

The wireless Vela Weather Station communicates via a wireless link with a MicroServer, Display Console or a computer running WeatherMaster software.

The system includes the Vela sensor transmitter an optional tipping bucket rain gauge, a pair of wireless transceivers and a weatherproof enclosure.

The server transceiver is located near the Vela sensor head and is housed in the weatherproof enclosure. A client transceiver is connected to the monitoring device. An optional RS-232 Interface Module is available to connect the wireless transceiver to multiple devices.

The 2.4GHz transceivers are capable of communicating at a distance of 1 mile with a good line-of-sight.

The 900MHz transceivers are capable of communicating at a distance of 20 miles with a good line-of-sight.

Vela 420 PLC System

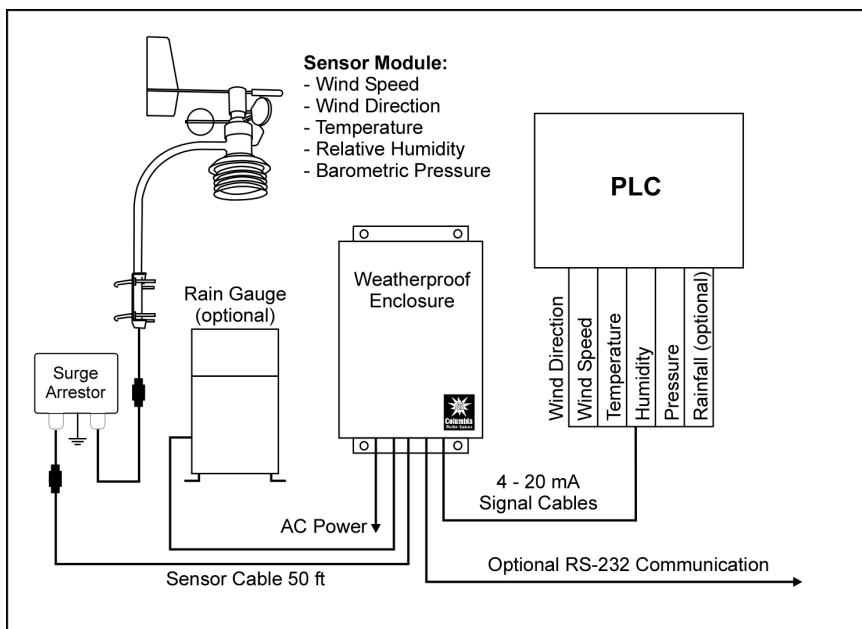

The Vela 420 Weather Station offers a complete weather station with 4-20 mA output for industrial PLC interface.

The station provides six 4-20mA output channels including wind direction, wind speed, temperature, relative humidity, barometric pressure, and as an option, rainfall.

Additional monitoring options, including the Weather Display Console, Weather MicroServer and WeatherMaster software can be connected to the system via an RS-232 cable.

Note: The 4-20mA converters source power to the load.

Vela 420 Enclosure

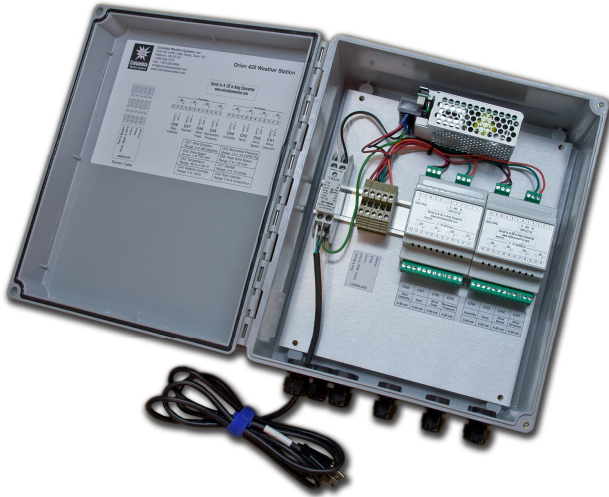

Serial to 4-20 m Amp Converter

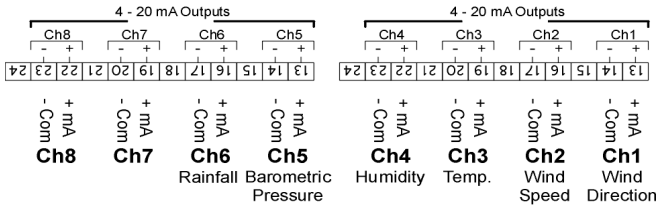

Ch1: Wind Direction Range: 0 to 360 degrees	Ch4: Relative Humidity Range: 0 to 100%
Ch2: Wind Speed Range: 0 to 112 mph	Ch5: Barometric Pressure Range: 14.77 to 32.5 inHg
Ch3: Temperature Range: -40 to +140°F	Ch6: Rainfall (Optional) 4mA: 0 in 20mA: 0.01 in

The Vela 420 outputs the following 6 parameters in 4-20 mA current signals:

Channel 1: Wind Direction

Description: Instantaneous wind direction.

Range: 0 to 360 degrees

Channel 2: Wind Speed

Description: Instantaneous wind speed.

Range: 0 to 112 mph (0 to 50 m/sec)

Channel 3: Temperature

Description: Instantaneous temperature.

Range: -40 °F to +140 °F (-40 °C to +60 °C)

Channel 4: Relative Humidity

Description: Instantaneous relative humidity.

Range: 0 to 100%

Channel 5: Barometric Pressure

Description: Instantaneous barometric pressure.

Range: 14.77 to 32.50 inches Hg. (500 – 1100 millibars)

Channel 6: Rainfall

Description: 0.01 inches rain accumulation.

4mA: 0 inches

20mA: 0.01 inches

Connecting the Vela Sensor Transmitter to the 420 Enclosure

Using a #1 Straight Slot screwdriver, attach the wires from the end of the sensor cable to the terminal block screws as shown below:

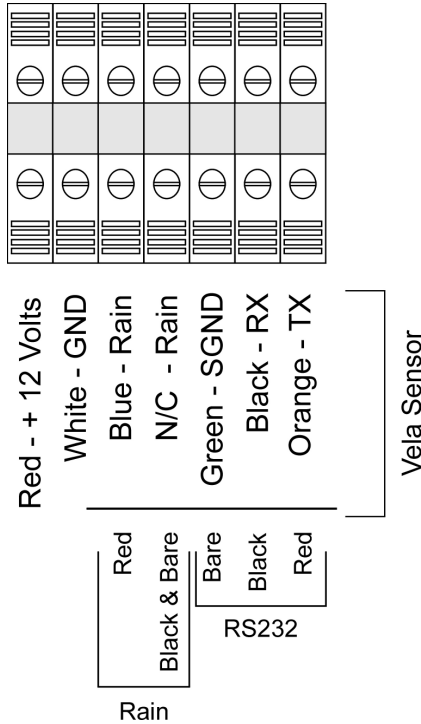

Attach the Red, Black and Bare wires from the end of the optional Tipping Bucket Rain Gauge to the terminal block screws as shown above.

To connect to an optional weather monitoring device such as the MicroServer, Display Console or a computer running WeatherMaster software; attach the wires from the end of the RS-232 cable to the terminal block screws as shown above.

SECTION 5: REPLACING THE TEMPERATURE/HUMIDITY MODULE

The temperature/relative humidity module can be replaced in the field in the event that the temperature or relative humidity readings are invalid.

Be sure to orient the module correctly to avoid damaging the sensors.

Follow the procedure below to replace the temperature/relative humidity module:

Kit Includes:

Temperature/Relative Humidity Module
Splash Shield with nut

Disassembly

1. Remove the 3 screws holding the radiation shield to the main sensor.



2. Supporting the radiation shield to protect the wires, remove the cap covering the circuit board.



3. Remove the 3 screws on the circuit board noting the orientation of the board as well as the location of the grounding lug.



4. The Temperature/Humidity Module is connected to an 8 pin header located on the other side of the board.

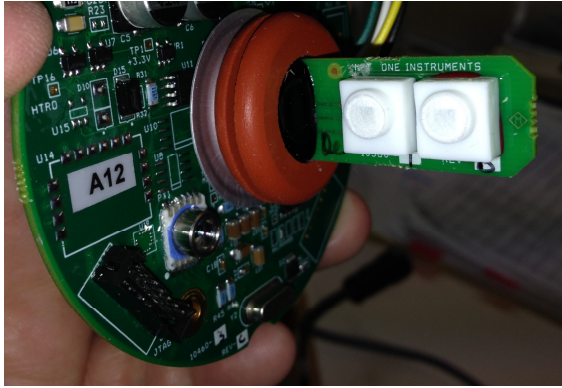

5. Remove and discard the rubber grommet and old Temp/RH Module. Also remove the rubber grommet inside the center of the radiation shield housing.

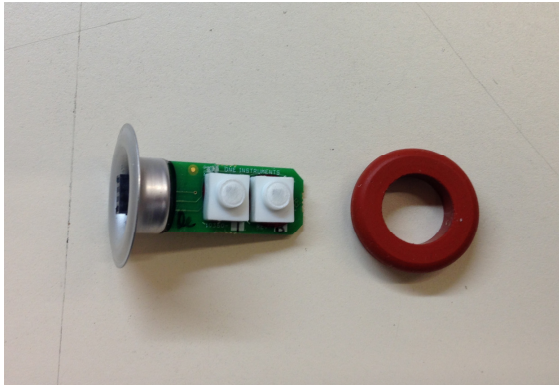

Reassembly

1. With the textured side up place the splash shield in the housing. Tighten the nut down to secure the splash shield.



2. Install the new Temp/RH Module onto the 8 pin connector ensuring that the white dot is facing the black J3 Connector.

Be sure to orient the module correctly to avoid damaging the sensors.

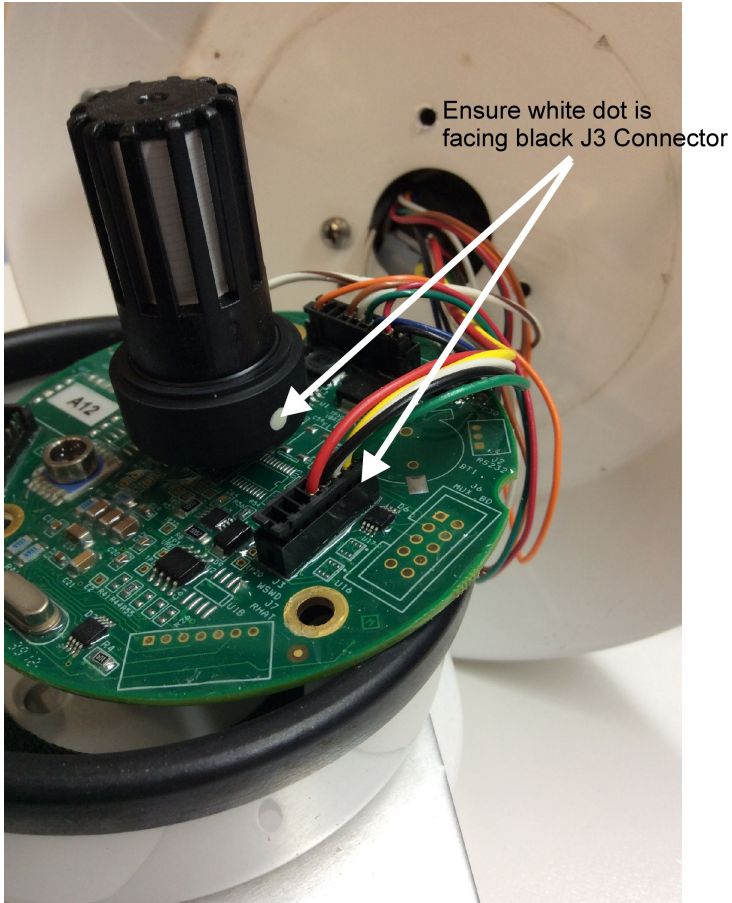

3. Carefully install the circuit board into the housing, wire side down, while guiding the module through the center of the housing.
4. Line up the three circuit board holes with the housing stand offs and reinstall the screws.
5. Replace the moisture shield over the circuit board.
6. Reinstall the radiation shield housing.

SECTION 6:

TROUBLESHOOTING

This chapter describes common problems, their probable causes and remedies.

Problem	Possible Cause	Action
Loss of communication from Vela sensor transmitter	Blown fuse	Check the Interface Module fuse, replace if needed.
	Poor cable connection	Check all cable connections between sensor and monitoring device.
	Surge protector tripped	Bypass the surge protector to determine if communication is restored. Replace or return for repair if needed.

Loss of communication with Vela sensor transmitter:

- Check the Interface Module. If the Green Power LED and Red Power LED are out, it is possible that the fuse has blown. Disconnect power and remove the four screws on the front panel of the Interface Module to check the fuse.
- Check all weatherproof cable connectors between the Vela sensor and any optional monitoring device; e.g., MicroServer, Display Console. Look for broken or damaged pins. Also inspect the cable connectors for water intrusion.
- If a surge protector was purchased and installed, an electrical event may have tripped the protector. Test for loss of communication by bypassing the surge protector and establish a direct cable connection. Determine if communication has been reestablished. To purchase a replacement surge protector please call 1-503-629-0887 and reference Part No. 8355.

SECTION 7: USER SUPPORT INFORMATION

This section consists of the following items:

1. **One-Year Limited Warranty:** Please read this document carefully.
2. **Return for Repair Procedure:** This procedure is for your convenience in the event you must return your Weather Station for repair or replacement. Follow the packing instructions carefully to protect your instrument in transit.

Limited Warranty

Columbia Weather Systems, Inc. (CWS), warrants the Vela Weather Station to be free from defects in materials and/or workmanship when operated in accordance with the manufacturer's operating instructions, for one (1) years from date of purchase, subject to the provisions contained herein. CWS warranty shall extend to the original purchaser only and shall be limited to factory repair or replacement of defective parts.

EXCLUSIONS

Certain parts are not manufactured by CWS (i.e., certain purchased options, etc.) and are therefore not covered by this warranty. These parts may be covered by warranties issued by their respective manufacturers and although CWS will not warrant these parts, CWS will act as agent for the administration of any such independent warranties during the term of this warranty. This warranty does not cover normal maintenance, damage resulting from improper use or repair, or abuse by the operator. Damage caused by lightning or other electrical discharge is specifically excluded. This warranty extends only to repair or replacement, and shall in no event extend to consequential damages. In the event of operator repair or replacement, this warranty shall cover neither the advisability of the repair undertaken, nor the sufficiency of the repair itself.

THIS DOCUMENT REFLECTS THE ENTIRE AND EXCLUSIVE UNDERSTANDING OF THE PARTIES, AND EXCEPT AS OTHERWISE PROVIDED HEREIN, ALL OTHER WARRANTIES, EXPRESS OR IMPLIED, PARTICULARLY THE WARRANTIES OF MERCHANT ABILITY AND/OR FITNESS FOR A PARTICULAR PURPOSE ARE EXCLUDED.

This warranty gives you specific legal rights, and you may also have other rights which vary from state to state.

Return for Repair Procedure

1. In the event of defects or damage to your unit, first call the Service Department Monday through Friday, 8:30 am to 4:00 pm PST, (503) 629-0887 to determine the advisability of factory repair. The Service Department will issue an RMA number (Return Merchandise Authorization) to help us identify the package when received. Please write that number on the outside of the box.
2. In the event factory service is required, return your Weather Station as follows:
 - A. Packing
 - ◆ Pack in original shipping carton or a sturdy oversized carton.
 - ◆ Use plenty of packing material.
 - B. Include:
 - ◆ A brief description of the problem with all known symptoms.
 - ◆ Your telephone number.
 - ◆ Your return street shipping address (UPS will not deliver to a P.O. box).
 - ◆ Write the RMA number on the outside of the box.
 - C. Shipping
 - ◆ Send freight prepaid (UPS recommended).
 - ◆ Insurance is recommended. (The factory can provide the current replacement value of the item being shipped for insurance purposes.)
 - D. Send to:

Columbia Weather Systems, Inc.
2240 NE Griffin Oaks Street, Suite 100
Hillsboro, Oregon 97124
 - E. C.O.D. shipments will not be accepted.
3. If your unit is under warranty, after repair or replacement has been completed, it will be returned by a carrier and method chosen by Columbia Weather, Inc. to any destination within the continental U.S.A. If you desire some other specific form of conveyance or if you are located beyond these borders, then you must bear the additional cost of return shipment.

4. If your unit is not under warranty, we will call you with an estimate of the charges. If approved, your repaired unit will be returned after all charges, including parts, labor and return shipping and handling, have been paid. If not approved, your unit will be returned as is via UPS COD for the amount of the UPS COD freight charges.

Reference

Glossary

Aspirating Radiation Shield

A device used to shield a sensor such as a temperature probe from direct and indirect radiation and rain while providing access for ventilation.

Barometric Pressure

The pressure exerted by the atmosphere as a consequence of gravitational attraction exerted upon the “column” of air lying directly above the point in question.

Celsius Temperature Scale

A temperature scale with the ice point at 0 degrees and the boiling point of water at 100 degrees.

Dew Point

The temperature to which a given parcel of air must be cooled at constant pressure and constant water-vapor content in order for saturation to occur. When this temperature is below 0°C, it is sometimes called the frost point.

Density Altitude

Density altitude is a meteorological variable that is important to pilots, especially during the summer. The density altitude is the altitude in a standard atmosphere where the density is the same as the given atmospheric density. During a hot muggy summer day, a pilot begins take off from an airport with an elevation of 2500 feet. Because of the warm temperature and the moisture in the air, the airplane has to work as if it was taking off at an airport at an elevation of 6000 feet resulting in the plane needing more power and a longer roll down the runway to take off.

Fahrenheit Temperature Scale

A temperature scale with the ice point at 32 degrees and the boiling point of water at 212 degrees.

Global Radiation

The total of direct solar radiation and diffused sky radiation received by a unit horizontal surface. Global radiation is measured by a Pyranometer.

Heat Index

The heat index or apparent temperature is a measure of discomfort due to the combination of heat and high humidity. It was developed in 1979 and is based on studies of evaporative skin cooling for combinations of temperature and humidity.

Pyranometer

It measures the combined intensity of incoming direct solar radiation and diffused sky radiation. The Pyranometer consists of a radiation-sensing element, which is mounted so that it views the entire sky.

Relative Humidity

Popularly called humidity. The ratio of the actual vapor pressure of the air to the saturation vapor pressure.

Sea Level Pressure

The atmospheric pressure at mean sea level, either directly measured or, most commonly, empirically determined from the observed station pressure.

In regions where the earth's surface pressure is above sea level, it is standard observational practice to reduce the observed surface pressure to the value that would exist at a point at sea level directly below.

Solar Radiation

The total electromagnetic radiation emitted by the sun. 99% of the sun's energy output falls within the wavelength interval from 0.15 microns to 4.0 microns, with peak intensity near 0.47 microns. About one-half of the total energy in the solar beam is contained within the visible spectrum from 0.4 to 0.7 microns, and most of the other half lies near infrared, a small additional portion lying in the ultraviolet.

Wind Chill

That part of the total cooling of a body caused by air motion.

Unit Conversion

Speed

Kilometers per hour = 1.610 x miles per hour

Knots = 0.869 x miles per hour

Meters per second = 0.448 x miles per hour

Feet per second = 1.467 x miles per hour

Temperature

Temperature in °C = 5/9 (temperature in °F - 32)

Temperature in °F = (1.8 x temperature in °C) + 32

Distance

Millimeters = 25.4 x inches

Pressure

Millibars = 33.86 x inches of mercury

Kilopascals = 3.386 x inches of mercury

Pounds per square inch = 0.49 x inches of mercury

Standard atmospheres = 0.0334 x inches of mercury

Tables and Formulas

Wind Chill Chart

In 2001, NWS implemented an updated Wind chill Temperature (WCT) index. The change improves upon the former WCT Index used by the NWS and the Meteorological Services of Canada, which was based on the 1945 Siple and Passel Index.

In the fall of 2000, the Office of the Federal Coordinator for Meteorological Services and Supporting Research (OFCM) formed a group consisting of several Federal agencies, MSC, the academic community (Indiana University-Purdue University in Indianapolis (IUPUI), University of Delaware and University of Missouri), and the International Society of Biometeorology to evaluate and improve the windchill formula. The group, chaired by the NWS, is called the Joint Action Group for temperature Indices (JAG/TI). JAG/TI's goal is to upgrade and standardize the index for temperature extremes internationally (e.g. Wind chill Index).

The current formula uses advances in science, technology, and computer modeling to provide a more accurate, understandable, and useful formula for calculating the dangers from winter winds and freezing temperatures.

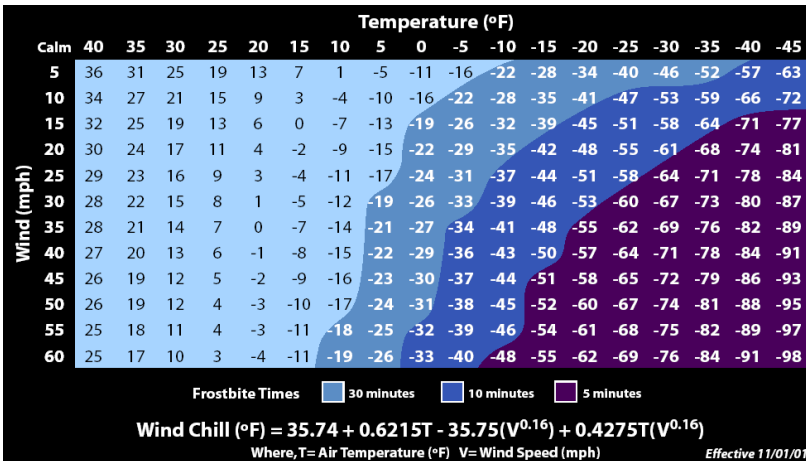

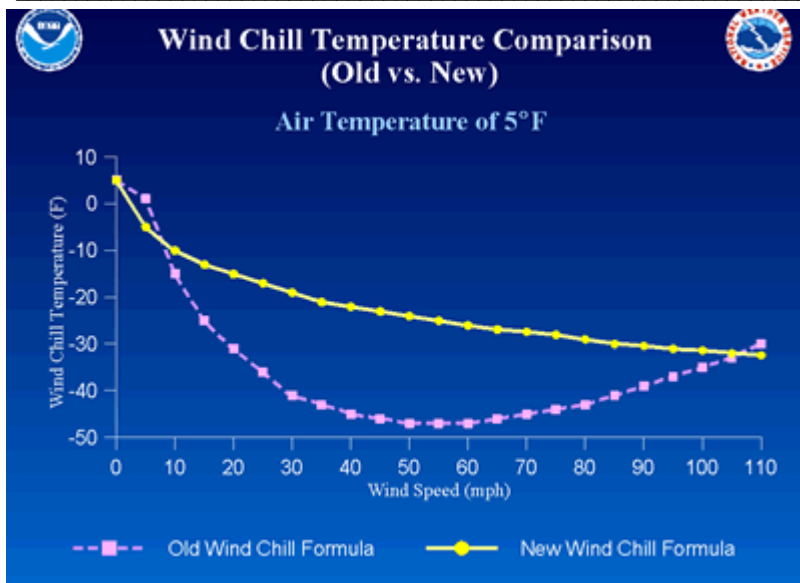

Wind Chill Equation

$$WC = 35.74 + 0.6215 T - 35.75(V^{0.16}) + 0.4275 T(V^{0.16})$$

Where:

WC = wind chill temperature in °F

V = wind velocity in mph

T = air temperature in °F

Note: Wind chill Temperature is only defined for temperatures at or below 50 degrees F and wind speeds above 3 mph.

Heat Index

RH	Temperature in °F													
	70	75	80	85	90	95	100	105	110	115	120	125	130	135
0	64	66	73	78	83	87	91	95	99	103	107	111	117	120
5	64	69	74	79	84	88	93	97	102	107	111	116	122	126
10	65	70	75	80	85	90	95	100	105	111	116	123	131	
15	65	71	76	81	86	91	97	102	108	115	123	131		
20	66	72	77	82	87	93	99	105	112	120	130	141		
25	66	72	77	83	88	94	101	109	117	127	139			
30	67	73	78	84	90	96	104	113	123	135	148			
35	67	73	79	85	91	98	107	118	130	143				
40	68	74	79	86	93	101	110	123	137	151				
45	68	74	80	87	95	104	115	129	143					
50	69	75	81	88	96	107	120	135	150					
55	69	75	81	89	98	110	126	142						
60	70	76	82	90	100	114	132	149						
65	70	76	83	91	102	119	138							
70	70	77	84	93	106	124	144							
75	70	77	85	95	109	130	150							
80	71	78	86	97	113	136								
85	71	78	87	99	117	140								
90	71	79	88	102	122	150								
95	71	79	89	105	126									
100	72	80	90	108	131									

Dew Point

$$B = (\ln (RH/100) + ((17.2694 * T) / (238.3 + T))) / 17.2694$$

$$\text{Dew Point in } ^\circ\text{C} = (238.3 * B) / (1 - B)$$

Where:

RH = Relative Humidity

T = Temperature in $^\circ\text{C}$

Ln = Natural logarithm



Columbia Weather Systems, Inc.
2240 NE Griffin Oaks Street, Suite 100
Hillsboro, OR 97124-6463

Telephone

(503) 629-0887

Fax

(503) 629-0898

Web Site

<http://www.columbiaweather.com>

Email

info@columbiaweather.com

Version 2.10

Printed in U.S.A.