



*Vela 420*TM

Weather Stations

Wind Speed & Direction | Temperature | Humidity | Pressure | 4-20 mA Output



www.columbiaweather.com



Innovative Weather Monitoring

Combining the ease of an all-in-one sensor package with the reliability and affordability of mechanical wind sensors, the Vela 420™ Weather Station offers a complete weather station for industrial PLC interface with:

- proven, reliable **wind speed** and **direction** sensor technology,
- **temperature** and **humidity** sensors in a radiation shield,
- solid state **barometric pressure** sensor, and
- optional tipping bucket **rain gauge**

The Vela 420 Weather Station features:

- Multi-Sensor Design -- easy installation with a single sensor cable
- 4-20 mA current output for all parameters
- One-year Warranty

Users can monitor weather data on PLC software such as Wonderware®. Additional data monitoring options include the Weather Display, WeatherMaster™ Software and the Weather MicroServer™ for Internet-ready weather data.

Vela 420 Weather Station System Diagram

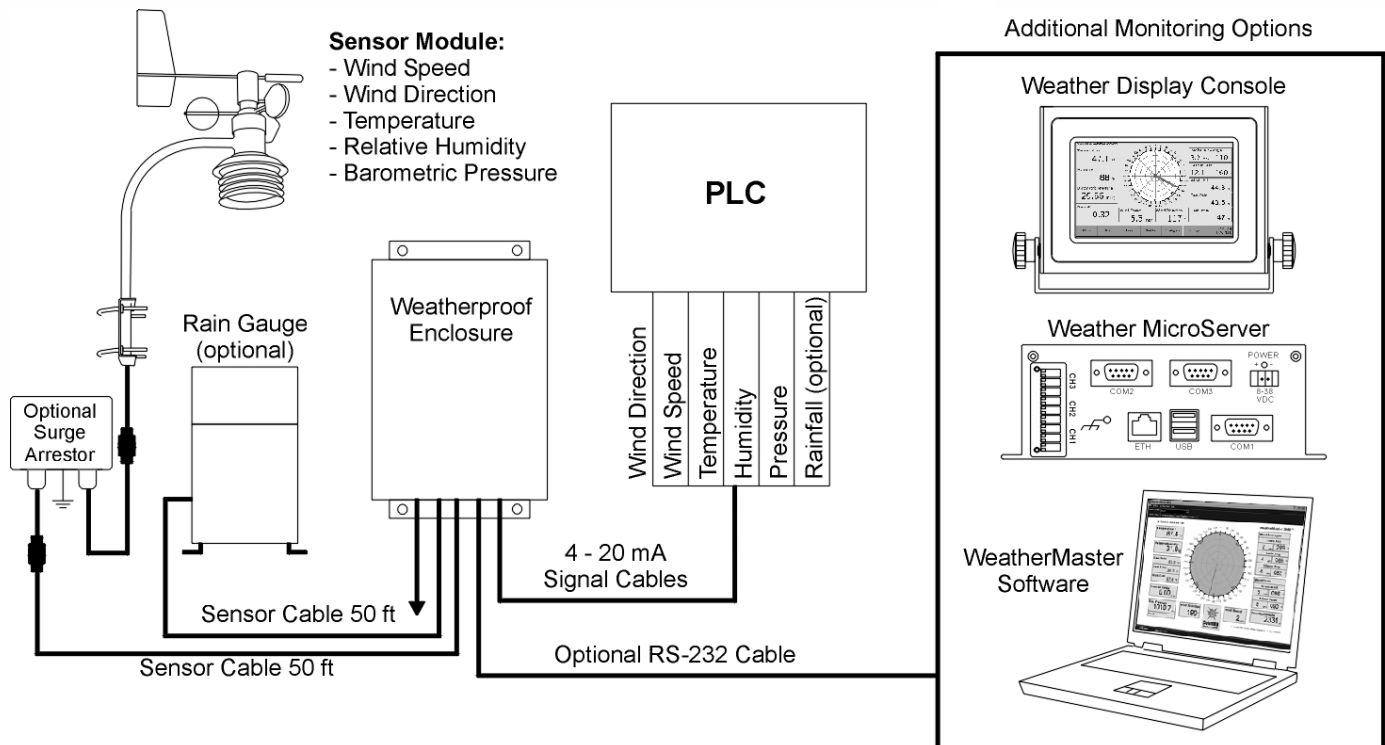

Call or email for a quote • toll-free 1 888-508-7375 • info@columbiaweather.com

Vela™ Weather Stations

Color Weather Display Console™

The Weather Display Console uses “intelligent” touch-screen technology. With its programmable microprocessor and abundant memory, the console displays weather information, performs complex computations, and stores data.

The Weather Display Console features a seven-inch, TFT color LCD panel with 800 x 480 pixels resolution. It can connect directly to the weather station with a serial port or to the Weather MicroServer utilizing existing Ethernet.

The display console is flexible and can be factory-programmed to suit specific market and industry requirements. It is available in three mounting options:

- Desktop/Wall-Mount
- Panel Mount/Flush Mount
- 19" Rack Mount



WeatherMaster™ Software

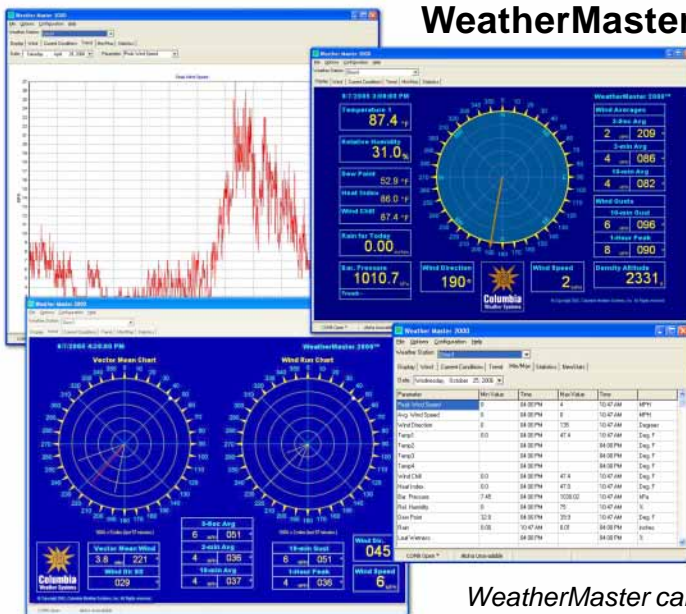

This professional-grade software is designed to optimize the capabilities of Vela Weather Stations. Providing real-time computer weather monitoring, WeatherMaster offers:

- Display and automatic logging of all measured and calculated parameters
- Downwind vector wind and wind character-plotting screens
- An open Microsoft Access® database for archival with easy retrieval and compatibility with other Windows® programs
- On-the-fly graphing and trend display of all parameters
- Alarm notification via computer, email, pager or cell phone
- Multi-station monitoring and data acquisition
- Quick-North orientation
- Interface with CAMEO/ALOHA software for plume modeling and evacuation corridor predictions

WeatherMaster can be customized to meet specific industry requirements.

Weather MicroServer™

The Weather MicroServer is a self-contained, proprietary computer utilizing an embedded Linux operating system. It creates an “Internet-ready” weather monitoring system by automatically providing FTP output, XML web service, and Internet browser user interface.

SNMP and Modbus/OPC communication protocols are standard for Industrial Management applications.

The Weather MicroServer has datalogging capability. It connects to your network with an included Ethernet cable.

Two serial ports offer interface to both the Weather Display Console and additional peripheral devices or sensors such as visibility and solar radiation.

The Weather MicroServer can provide real-time weather data to WeatherMaster Software over the network. This allows users to simultaneously monitor the weather using WeatherMaster on any network computer.



Weather MicroServer Optional Sensors:

The **visibility** sensor measures atmospheric visibility (meteorological optical range) by determining the amount of light scattered by particles (smoke, dust, haze, fog, rain, and snow) in the air that pass through the optical sample volume. A 42-degree forward scatter angle is used to ensure performance over a wide range of particle sizes.

The pyranometer or **solar radiation** sensor measures the shortwave radiation reaching the Earth's surface.

The self-cleaning convex lens measures even low-angle radiation directly from the sun in the morning and evening. The dome-shaped head prevents water accumulation.



Call or email for a quote • toll-free 1 888-508-7375 • info@columbiaweather.com

Sensor Specifications

Temperature

Range: -40 to +60 °C (-40 to +140°F)
Accuracy: $\pm 0.5^\circ$ C
Resolution: 0.1° C

Barometric Pressure

Range: 500 to 1100 mbars
Accuracy: ± 2 mbars
Resolution: 0.1 mbar

Wind Speed

Range: 0 to 50 m/sec (0 to 112 mph)
Accuracy: $\pm 2\%$
Resolution: 0.1 m/s
Threshold: 1.0 m/sec

Wind Direction

Range: 0 to 360°
Accuracy: $\pm 5^\circ$
Resolution: 1.0°
Threshold: 1.0 m/sec

Relative Humidity

Range: 0 to 100%
Accuracy: $\pm 4\%$
Resolution: 1.0%

Optional Tipping Bucket Rain Gauge

Accuracy: $\pm 1\%$ at 2 in/hr or less
Resolution: 0.01 inch

Vela 420™ Weather Stations

Sensor Descriptions

Wind Speed and Direction

A three-cup anemometer is used for accuracy, sensitivity and durability. The cups are connected to a shaft which turns a sensing element that converts the rotation into a series of electronic pulses. The basic operation is based on a field-proven, reliable design.

A lightweight vane tail provides the motive power for the wind direction portion of the sensor. As the vane tail moves, it turns a shaft on a pair of bearings. That shaft turns a sensing element that converts the rotation into analog voltage.

Temperature and Humidity

Both temperature and humidity are built into the radiation shield at the bottom of the sensor module. The integral shield limits errors due to solar radiation. The humidity sensor is a capacitive element enclosed in a protective membrane.

Air Pressure

A solid state pressure sensor built into the sensor electronics provides accurate measurement of barometric pressure changes over a wide range. Electronic temperature compensation is included for highest accuracy over the operating temperature of the sensor.

Optional Rain Gauge

The tipping bucket electric rain gauge is composed of a complex spun collector funnel with a knife edge that diverts the water to a tipping bucket mechanism. For each tip, a magnet causes an electronic pulse that is recorded. The rainfall sensor is completely automatic - spent water drains out of the bottom of the housing, hence, the instrument requires no servicing.

Additional Calculated Parameters

Through WeatherMaster Software or the Weather MicroServer, data from these sensors are computed to provide calculated parameters including Dew Point, Heat Index, Wind Chill, Degree-Day Temperatures and Density Altitude.

Vela 420 System Includes:

- Vela Sensor Transmitter with 50 foot cable
- Weatherproof Enclosure with two 4-20 mA converter modules and power supply

Please contact us today for a free quotation!



Columbia Weather Systems, Inc.
5285 NE Elam Young Pkwy, Suite C100
Hillsboro, OR 97124
Toll-free 1 888 508-7375
Phone (503) 629-0887
Fax (503) 629-0898
info@columbiaweather.com
www.columbiaweather.com