Pegasus FlyAway Kit

EX Model

A Portable Weather Station

User Manual

Version 1.20

All specifications subject to change without notice.

Printed in U. S. A.

© Copyright 2003-2010 Columbia Weather Systems, Inc. All Rights Reserved.

Proprietary Notice: Pegasus EX FlyAway Kit, Capricorn 2000, Capricorn 2000MP, Orion and Weather MicroServer are trademarks of Columbia Weather Systems, Inc. The information and drawings contained herein are the sole property of Columbia Weather Systems, Inc. Use of this publication is reserved exclusively for customers of Columbia Weather Systems, Inc. and their personnel. Reproduction of this material is forbidden without the express written consent of Columbia Weather Systems, Inc.



Columbia Weather Systems, Inc.
2240 NE Griffin Oaks Street, Suite 100
Hillsboro, OR 97124-6463

Telephone
(503) 629-0887

Fax
(503) 629-0898

Web Site
<http://www.columbiaweather.com>

Email
info@columbiaweather.com

Catalog Number: 81643
Version 1.10

Printed in U.S.A.

Welcome!

Congratulations on your purchase of the Pegasus EX FlyAway Kit Portable Weather Station.

Please read this manual completely prior to installation.

Important Notice: Shipping Damage

BEFORE YOU READ ANY FURTHER, please inspect all system components for obvious shipping damage. The Pegasus EX FlyAway Kit is a high precision instrument and can be damaged by rough handling. Your unit was packaged to minimize the possibility of damage in transit. Therefore, we recommend that you save the shipping container for any future shipment of your Pegasus EX unit.

In the event your order arrives in damaged condition, it is important that the following steps be taken immediately. The title transfers automatically to you, the customer, once the material is entrusted to the transport company.

NOTE: DO NOT RETURN THE INSTRUMENT TO COLUMBIA WEATHER SYSTEMS until the following steps are completed. Failure to follow this request will jeopardize your claim.

1. Open the container and inspect the contents. Do not throw away the container or any damaged parts. Try to keep items in the same condition as originally received.
2. Notify the transport company immediately in writing, preferably by facsimile, about the shipping damage.
3. Wait for the transport company's representative to inspect the shipment personally.
4. After inspection, request permission from Columbia Weather Systems for return of the damaged instrument by calling the Capricorn Service Department, (503) 629-0887.
5. Return approved items to us at the following address:

Columbia Weather Systems, Inc.

2240 NE Griffin Oaks Street, Suite 100

Hillsboro, OR 97124

6. After return authorization is issued and we receive the instrument, an estimate of the cost of repair will be sent to you for submittal to the transport company as a claim.

Dew Point

$$B = (\ln (RH/100) + ((17.2694 * T) / (238.3 + T))) / 17.2694$$

$$\text{Dew Point in } ^\circ\text{C} = (238.3 * B) / (1 - B)$$

Where:

RH = Relative Humidity

T = Temperature in $^\circ\text{C}$

Ln = Natural logarithm

Heat Index

RH	Temperature in °F													
	70	75	80	85	90	95	100	105	110	115	120	125	130	135
0	64	66	73	78	83	87	91	95	99	103	107	111	117	120
5	64	69	74	79	84	88	93	97	102	107	111	116	122	126
10	65	70	75	80	85	90	95	100	105	111	116	123	131	
15	65	71	76	81	86	91	97	102	108	115	123	131		
20	66	72	77	82	87	93	99	105	112	120	130	141		
25	66	72	77	83	88	94	101	109	117	127	139			
30	67	73	78	84	90	96	104	113	123	135	148			
35	67	73	79	85	91	98	107	118	130	143				
40	68	74	79	86	93	101	110	123	137	151				
45	68	74	80	87	95	104	115	129	143					
50	69	75	81	88	96	107	120	135	150					
55	69	75	81	89	98	110	126	142						
60	70	76	82	90	100	114	132	149						
65	70	76	83	91	102	119	138							
70	70	77	84	93	106	124	144							
75	70	77	85	95	109	130	150							
80	71	78	86	97	113	136								
85	71	78	87	99	117	140								
90	71	79	88	102	122	150								
95	71	79	89	105	126									
100	72	80	90	108	131									

Table of Contents

WELCOME!	3
IMPORTANT NOTICE: SHIPPING DAMAGE	4
SECTION 1: INTRODUCTION	9
THE PEGASUS EX SYSTEM	9
SPECIFICATIONS.....	9
<i>Temperature</i>	9
<i>Barometric Pressure</i>	9
<i>Wind Speed</i>	10
<i>Wind Direction</i>	10
<i>Relative Humidity</i>	10
<i>Wireless Transceiver</i>	10
<i>Battery Power</i>	10
<i>Control Module</i>	10
<i>System Weight</i>	11
SECTION 2: PHYSICAL DESCRIPTION.....	13
CONTROL MODULE.....	14
TEMPERATURE SENSOR.....	16
RELATIVE HUMIDITY SENSOR	17
TRIPOD	18
<i>Specifications</i>	19
WEATHERMASTER™ SOFTWARE (OPTIONAL)	21
WEATHER VIEW 32™ SOFTWARE (OPTIONAL)	22
WEATHER DISPLAY CONSOLE (OPTIONAL)	23
SECTION 3: INSTALLATION	25
SECTION 4: DISPLAY CONSOLE AND SOFTWARE INSTALLATION.....	31
WEATHER DISPLAY CONSOLE	31
WEATHERMASTER™ SOFTWARE.....	31
WEATHER VIEW 32™ SOFTWARE.....	31
SECTION 5: OPERATION.....	33
RS-232 MODEM SERIAL PORT.....	33
RS-232 AUX SERIAL PORT	33
COMMUNICATION	33
SETTING DATE AND TIME	34
DISPLAYING DATE AND TIME	34

DISPLAYING CURRENT SENSOR READINGS	34
<i>The POLL command</i>	34
<i>The SAMPLE command</i>	35
<i>The Short commands</i>	35
DATALOG	36
SETTING DATALOG INTERVALS	36
SETTING HI/LO INTERVALS.....	36
DISPLAYING THE DATALOG.....	37
RESETTING HI/LO	38
RESETTING THE DATALOG	38
DISPLAYING CURRENT HI/LO.....	38
SETTING BAROMETRIC PRESSURE ALTITUDE AND OFFSET	39
DISPLAY CURRENT SETTINGS	39
CONTINUOUS DISPLAY OF DIRECTION	39
CONTINUOUS DISPLAY OF WIND INFORMATION.....	39

SECTION 6: CALIBRATION.....43

CALIBRATING THE BAROMETRIC PRESSURE SENSOR.....	43
<i>Altitude Setting</i>	43
<i>Optional Calibration Procedure</i>	43
CALIBRATING THE WIND SENSORS.....	44
CALIBRATING THE TEMPERATURE SENSORS.....	44
CALIBRATING THE HUMIDITY SENSOR	45

SECTION 7: MAINTENANCE47

CONTROL MODULE.....	47
TEMPERATURE SENSOR MAINTENANCE.....	47
WIND SENSOR MAINTENANCE.....	47
RELATIVE HUMIDITY SENSOR MAINTENANCE.....	48

SECTION 8: TROUBLESHOOTING.....49

TEMPERATURE SENSOR TROUBLESHOOTING	49
COMMUNICATION PROBLEMS	49

SECTION 9: USER SUPPORT INFORMATION51

LIMITED WARRANTY.....	51
<i>EXCLUSIONS</i>	51
RETURN FOR REPAIR PROCEDURE	52

REFERENCE.....55

GLOSSARY	55
<i>Aspirating Radiation Shield</i>	55
<i>Barometric Pressure</i>	55
<i>Celsius Temperature Scale</i>	55
<i>Dew Point</i>	55
<i>Fahrenheit Temperature Scale</i>	55

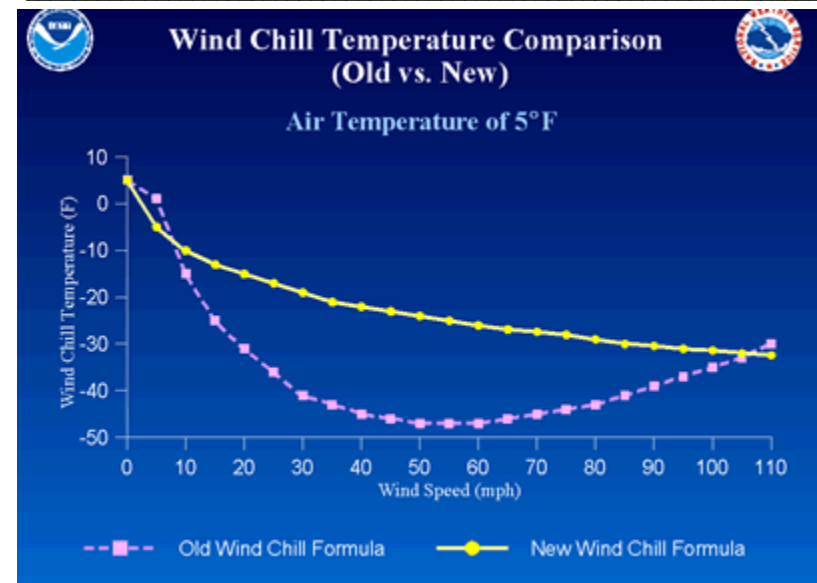

Wind Chill Equation

$$WC = 35.74 + 0.6215 T - 35.75(V^{0.16}) + 0.4275 T(V^{0.16})$$

Where:

WC = wind chill temperature in °F

V = wind velocity in mph

T = air temperature in °F

Note: Wind chill Temperature is only defined for temperatures at or below 50 degrees F and wind speeds above 3 mph.

Tables and Formulas

Wind Chill Chart

In 2001, NWS implemented an updated Wind chill Temperature (WCT) index. The change improves upon the former WCT Index used by the NWS and the Meteorological Services of Canada, which was based on the 1945 Siple and Passel Index.

In the fall of 2000, the Office of the Federal Coordinator for Meteorological Services and Supporting Research (OFCM) formed a group consisting of several Federal agencies, MSC, the academic community (Indiana University-Purdue University in Indianapolis (IUPUI), University of Delaware and University of Missouri), and the International Society of Biometeorology to evaluate and improve the windchill formula. The group, chaired by the NWS, is called the Joint Action Group for temperature Indices (JAG/TI). JAG/TI's goal is to upgrade and standardize the index for temperature extremes internationally (e.g. Wind chill Index).

The current formula uses advances in science, technology, and computer modeling to provide a more accurate, understandable, and useful formula for calculating the dangers from winter winds and freezing temperatures.

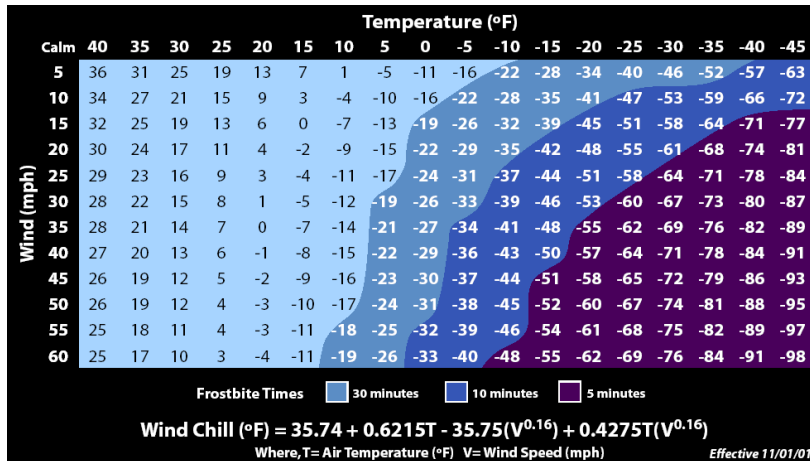

Heat Index..... 55

Relative Humidity..... 56

Sea Level Pressure..... 56

Wind Chill..... 56

UNIT CONVERSION 57

Speed..... 57

Temperature..... 57

Distance 57

Pressure 57

TABLES AND FORMULAS..... 58

Wind Chill Chart..... 58

Wind Chill Equation 59

Heat Index..... 60

Dew Point 61

Unit Conversion

Speed

Kilometers per hour = 1.610 x miles per hour

Knots = 0.869 x miles per hour

Meters per second = 0.448 x miles per hour

Feet per second = 1.467 x miles per hour

Temperature

Temperature in °C = 5/9 (temperature in °F - 32)

Temperature in °F = (1.8 x temperature in °C) + 32

Distance

Millimeters = 25.4 x inches

Pressure

Millibars = 33.86 x inches of mercury

Kilopascals = 3.386 x inches of mercury

Pounds per square inch = 0.49 x inches of mercury

Standard atmospheres = 0.0334 x inches of mercury

Relative Humidity

Popularly called humidity. The ratio of the actual vapor pressure of the air to the saturation vapor pressure.

Sea Level Pressure

The atmospheric pressure at mean sea level, either directly measured or, most commonly, empirically determined from the observed station pressure.

In regions where the earth's surface pressure is above sea level, it is standard observational practice to reduce the observed surface pressure to the value that would exist at a point at sea level directly below.

Wind Chill

That part of the total cooling of a body caused by air motion.

SECTION 1: INTRODUCTION

The Pegasus EX System

The Pegasus EX FlyAway Kit portable weather station combines digital quality and professional-grade equipment with the need for a highly mobile weather station to create a state-of-the-art, rapid deployment weather monitoring system for Emergency Operations.

Pegasus EX is specifically designed for firefighters, HazMat, Emergency Management, and Disaster Preparedness personnel when weather monitoring is crucial to the public's safety.

Pegasus EX allows Accident and Incident Commanders to create a fully functional weather operation within minutes, automatically collecting weather data and providing a cost-effective force-multiplier not available in any other portable weather station.

Specifications

Temperature

Type: digital semiconductor

Range: -67° to 257°F

Accuracy: $\pm 0.9^\circ\text{F}$ from +14° to 185°F ($\pm 0.5^\circ\text{C}$ from -10° to 85°C)
 $\pm 3.6^\circ\text{F}$ from -67° to 257°F ($\pm 2.0^\circ\text{C}$ from -55° to 125°C)

Resolution: 0.01 °F

Barometric Pressure

The barometric pressure sensor is located inside the Control Module and is part of the weather station circuit board.

Type: silicon shear stress strain gauge; temperature compensated and calibrated

Range: 27 to 33.96 in. Hg

Accuracy: ± 0.03 in. Hg over range (at sea level, with temperature between 32° and 182°F)

Resolution: 0.01 in. Hg

Wind Speed

Type: Sealed reed switch

Accuracy: ± 0.25 mph from 0 to 23 mph, $\pm 1\%$ from 24 to 160 mph

Range: 0 to 160 mph (139 knots)

Resolution: 1 mph

Starting Threshold: 0.9 mph

Wind Direction

Type: Precision Potentiometer

Resolution: 2 degrees

Mechanical Range: 0 to 360 degrees

Electrical Range: 0 to 356 degrees

Accuracy: ± 4 degrees

Relative Humidity

Type: Capacitance

Range: 0 to 100%

Accuracy: $\pm 3\%$ (or better) from 10 to 90% RH at 68° F

Stability: $\pm 2\%$ RH over 2 years

Resolution: 1% RH

Wireless Transceiver

Frequency: 2.402 - 2.478 GHz, FHSS (license-free)

Range: Up to 500 feet (152 m) indoors; Up to 10,000 feet (3050 m) line-of-sight

Output Power: 200 mW

Battery Power

Output: 12 VDC, 12 AH, 32-hour operation

SLA (Sealed Lead Acid) Gel Batteries

Control Module

Dimensions: 14 x 11 x 6.5 inches

Weight: 6.7 lbs/3 kg.

Reference

Glossary

Aspirating Radiation Shield

A device used to shield a sensor such as a temperature probe from direct and indirect radiation and rain while providing access for ventilation.

Barometric Pressure

The pressure exerted by the atmosphere as a consequence of gravitational attraction exerted upon the "column" of air lying directly above the point in question.

Celsius Temperature Scale

A temperature scale with the ice point at 0 degrees and the boiling point of water at 100 degrees.

Dew Point

The temperature to which a given parcel of air must be cooled at constant pressure and constant water-vapor content in order for saturation to occur. When this temperature is below 0°C or 32°F, it is sometimes called the frost point.

Fahrenheit Temperature Scale

A temperature scale with the ice point at 32 degrees and the boiling point of water at 212 degrees.

Heat Index

The heat index or apparent temperature is a measure of discomfort due to the combination of heat and high humidity. It was developed in 1979 and is based on studies of evaporative skin cooling for combinations of temperature and humidity.

System Weight

Weather station and carrying case: 52 lbs

Tripod and canvas bag: 17 lbs

Battery system and case: 24 lbs

- D. Send to:
- Columbia Weather Systems, Inc.
2240 NE Griffin Oaks Street, Suite 100
Hillsboro, Oregon 97124
- E. C.O.D. shipments will not be accepted.
3. If your unit is under warranty, after repair or replacement has been completed, it will be returned by a carrier and method chosen by Columbia Weather, Inc. to any destination within the continental U.S.A. If you desire some other specific form of conveyance or if you are located beyond these borders, then you must bear the additional cost of return shipment.
4. If your unit is not under warranty, we will call you with an estimate of the charges. If approved, your repaired unit will be returned after all charges, including parts, labor and return shipping and handling, have been paid. If not approved, your unit will be returned as is via UPS COD for the amount of the UPS COD freight charges.

ABILITY AND/OR FITNESS FOR A PARTICULAR PURPOSE ARE EXCLUDED.

This warranty gives you specific legal rights, and you may also have other rights which vary from state to state.

Return for Repair Procedure

1. In the event of defects or damage to your system, first call the factory Capricorn Service Department Monday through Friday, 8:30 am to 4:00 pm PST, (503) 629-0887 to determine the advisability of factory repair. The Service Department will issue an RMA number (Return Merchandise Authorization) to help us identify the package when received. Please place that number on the outside of the box.
2. In the event factory service is required, return your Pegasus EX Weather Station as follows:
 - A. Packing
 - ◆ Wrap sensor or component in a plastic bag first.
 - ◆ Pack in original shipping carton or a sturdy oversized carton.
 - ◆ Use plenty of packing material.
 - B. Include:
 - ◆ A brief description of the problem with all known symptoms.
 - ◆ Your phone number.
 - ◆ Your return street shipping address (UPS will not deliver to a P.O. box).
 - ◆ Write the RMA number on the outside of the box.
 - C. Shipping
 - ◆ Send freight prepaid (UPS recommended).
 - ◆ Insurance is recommended. (The factory can provide the current replacement value of the item being shipped for insurance purposes.)

SECTION 2: PHYSICAL DESCRIPTION



Control Module



The Control Module consists of the System board and a 2.4 GHz transceiver housed in a weatherproof fiber glass enclosure with external sensor and power connectors.

The System board has an on-board barometric pressure sensor and a system fuse (including a spare fuse). The System board also has in-line rechargeable batteries to preserve the datalog and system configuration when power is absent.

The Control Module dimensions are: 10 x 8.5 x 3.5 inches and weighs: 6.7 lbs/3 kg.

SECTION 9: USER SUPPORT INFORMATION

This section consists of the following items:

1. Two-Year Limited Warranty: Please read this document carefully.
2. Return for Repair Procedure: This procedure is for your convenience in the event you must return your Pegasus EX or components for repair or replacement. Follow the packing instructions carefully to protect your instrument in transit.

Limited Warranty

Columbia Weather Systems, Inc. (CWS), warrants the Pegasus EX Weather Station to be free from defects in materials and/or workmanship when operated in accordance with the manufacturer's operating instructions, for two (2) years from date of purchase, subject to the provisions contained herein. CWS warranty shall extend to the original purchaser only and shall be limited to factory repair or replacement of defective parts.

EXCLUSIONS

Certain parts are not manufactured by CWS (i.e., certain purchased options, etc.) and are therefore not covered by this warranty. These parts may be covered by warranties issued by their respective manufacturers and although CWS will not warrant these parts, CWS will act as agent for the administration of any such independent warranties during the term of this warranty. This warranty does not cover normal maintenance, damage resulting from improper use or repair, or abuse by the operator. Damage caused by lightning or other electrical discharge is specifically excluded. This warranty extends only to repair or replacement, and shall in no event extend to consequential damages. In the event of operator repair or replacement, this warranty shall cover neither the advisability of the repair undertaken, nor the sufficiency of the repair itself.

THIS DOCUMENT REFLECTS THE ENTIRE AND EXCLUSIVE UNDERSTANDING OF THE PARTIES, AND EXCEPT AS OTHERWISE PROVIDED HEREIN, ALL OTHER WARRANTIES, EXPRESS OR IMPLIED, PARTICULARLY THE WARRANTIES OF MERCHANT

3. Check the line-of-site between the Pegasus EX and the monitoring device. If the line-of-site is not direct, try moving the Pegasus EX to an unobstructed location.

Wind sensor

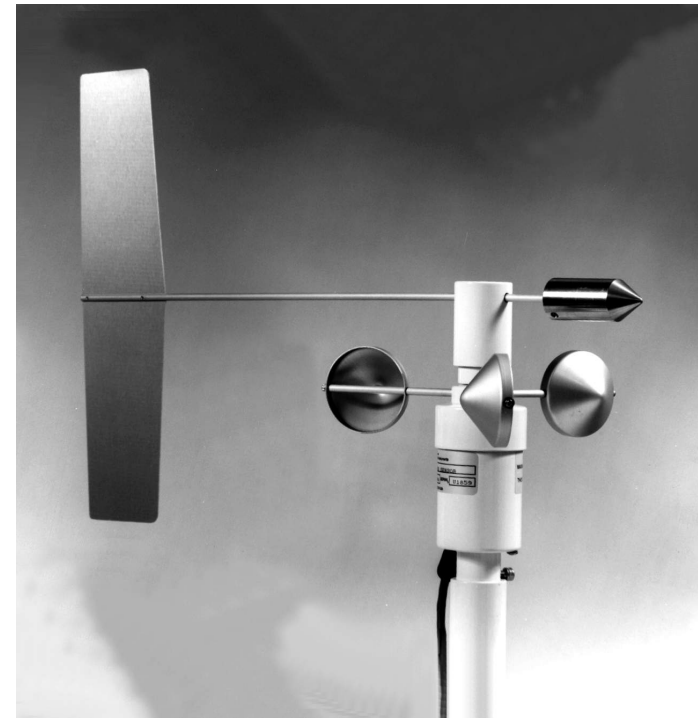

Note: Please refer to the Met One 034B wind sensor user manual for detailed installation, calibration and maintenance information

The Model 034B Wind Sensor combines wind speed and direction measurements into a single sensing unit.

The 034B Wind Sensor installs in minutes and provides accurate, long term, continuous monitoring in hostile environments.

Features

- Wind speed and direction in a single sensor
- Long field life
- Durable aluminum and stainless steel construction
- Low starting threshold
- Stainless steel bearings
- Ultra low power operation
- Easy maintenance

Temperature sensor

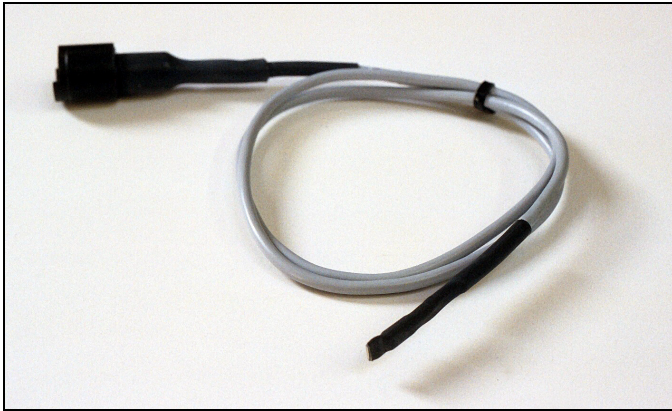

The Pegasus EX comes standard with one temperature sensor with 10 feet of cable. This digital, semiconductor-type probe reduces susceptibility to noise interference, and increases accuracy.

Section 8: Troubleshooting

Temperature Sensor Troubleshooting

If the Temperature sensor is reading a few degrees off when compared to a standard, the Temperature sensor may require re-calibration. Please refer to calibration procedure in Section 6: Calibrating the Temperature Sensor.

If the Temperature sensor is reading 255°F, the Temperature sensor may be disconnected from the Control Module. Check the cable from the sensor to the Control Module for any cuts or kinks. Check any splices to ensure good connection. Check the cable connection to the Control Module.

If replacing a Temperature sensor, all the new Temperature sensors and any other Temperature sensors connected to the Control Module should be re-initialized as follows:

1. Disconnect the temperature sensor from the Control Module.
2. Disconnect the power connector from the Control Module
3. Reapply power to the Control Module
4. Connect the temperature sensor to the Control Module
5. Disconnect the power connector from the Control Module
6. Reapply power to the Control Module

The temperature sensor is now initialized and should be reading the correct values.

Communication Problems

If the Pegasus EX is not communicating with the computer software or the Weather Display, please check the following:

1. Check power connections to the Control Module. Check the power LED on the circuit board inside the Control Module enclosure. If the light is not on, make sure the battery connected to the system is charged. Also check the on-board fuse. If blown, replace with the spare fuse located in the middle of the board.
2. Check all communication cable/connectors to be sure they are firmly connected.

Relative Humidity Sensor Maintenance

The Relative Humidity sensor does not require any field maintenance.

Relative Humidity sensor



This optional capacitive relative humidity sensor is compact and easy to use. It is easily installed in the self-aspirating radiation shield for protection from the sun and rain. This sensor offers long-term stability with minimal drift. Because the sensor is a capacitive device, it will not be affected by surface contamination in unclean environments. Since the sensor element is socketed and laser trimmed it can be easily replaced in the field without any additional calibration. The relative humidity sensor comes with a standard 10-foot cable and a quick disconnect connector.

Tripod

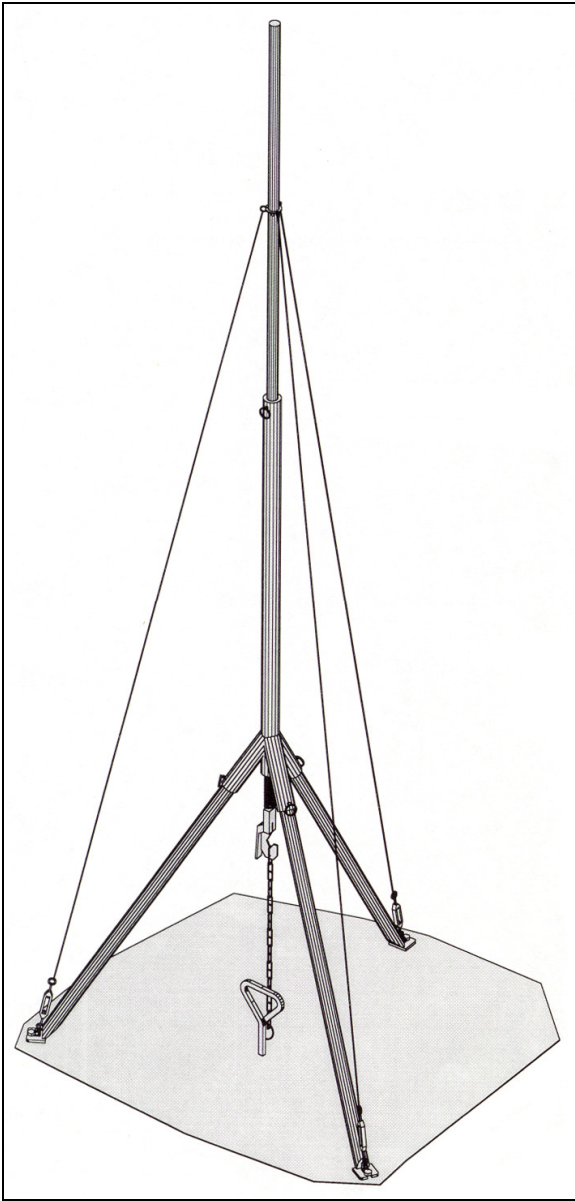

The meteorological tripod is designed to provide up to 10 feet of stable, secure support for your meteorological sensors.

Constructed from welded aluminum and is powder coated for appearance and longevity. The 15-pound tripod can easily support up to

SECTION 7: MAINTENANCE

In normal use, the Pegasus EX should require very little maintenance. In the event of any problems, follow the procedures contained in Section 8: Troubleshooting, to determine whether the components are defective. If defective and needs to be returned to the factory for repair, refer to the Return For Repair Procedure in Section 9: User Support Information.

Control Module

The Control Module contains sensitive electronic components and should not be serviced by the user. If the LED on the inside circuit board is not on, check for proper installation of the battery supply system. Check to see if the fuse on the Control Module board needs to be replaced. If necessary, replace it with a 1.0 amp 250V fast acting fuse.

Barometric Pressure Sensor Maintenance

The barometric pressure sensor is located inside the weatherproof enclosure and should not be serviced by the user.

Temperature Sensor Maintenance

Check the temperature sensor cables during installation and periodically thereafter to make sure they contain no cuts, kinks or other abnormalities.

Wind Sensor Maintenance

Please refer to the Met One 034B wind sensor user manual for detailed installation, calibration and maintenance information.

60 pounds of equipment. The tie-down kit allows for additional security in high-wind areas.

Set up takes less than five minutes. Simply insert the legs into the main body and install the stainless steel retainer pins. Extend the mast to the desired height and insert another retainer pin. Install the guy wires and you're ready to go!

Specifications

Capacity: Supports up to 60 lbs.

Shipping Weight: 17lbs

Shipping Box Dimensions: 70" x 8" x 8"

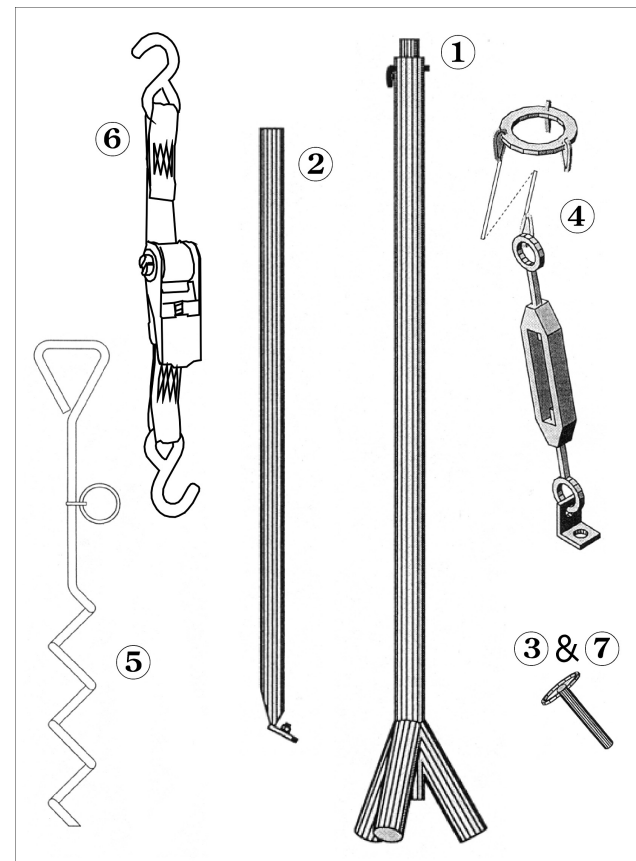

Item #	Description	Qty
1	Body/Mast Assembly	1
2	Legs	3

3	Retainer Pins	4
4	Guy Wire Ring with 3 Wires and Turnbuckles	1
5	Anchor Screw with Chain	1
6	Clamp with Strap	1
7	Retainer Pin	1

Calibrating the Humidity Sensor

The humidity sensor is calibrated at the factory and is traceable to NIST. No field calibration is required.

Calibrating the Wind Sensors

The wind speed sensor contains no components that can be calibrated by the user. Refer to the Installation Section for sensor North orientation.

Calibrating the Temperature Sensors

All Temperature sensors are calibrated at the factory to a superior grade ASTM mercury thermometer traceable to NIST. The calibration offset is recorded on the temperature sensor and on the end of the cable.

After initializing all the temperature sensors, enter the temperature offsets using the TCAL command. Please refer to Section 4: Operation for more information. TCAL offsets are labeled on the sensor cable.

To calibrate the temperature sensors on-site, perform the following steps:

Prepare an ice bath by mixing two cups of crushed ice in two cups of water. Use an insulated container for best results. Allow the temperature throughout the ice bath to stabilize by waiting for about twenty minutes.

Stir the ice bath to mix the ice and water, wait for the ice to separate from the water, place the temperature sensor in the ice bath. Make sure that the sensor is not in direct contact with ice.

Take a temperature reading from the Pegasus EX using SAMPLE or POLL.

Calculate the temperature offset as follows:

Temperature offset = (32 – Pegasus EX reading) * 100

Enter the temperature offset using the TCAL command. Please refer to Section 4: Operation for more information.

Record the temperature offset on a label attached to the sensor.

Repeat the process for any other temperature sensor.

WeatherMaster™ Software (optional)

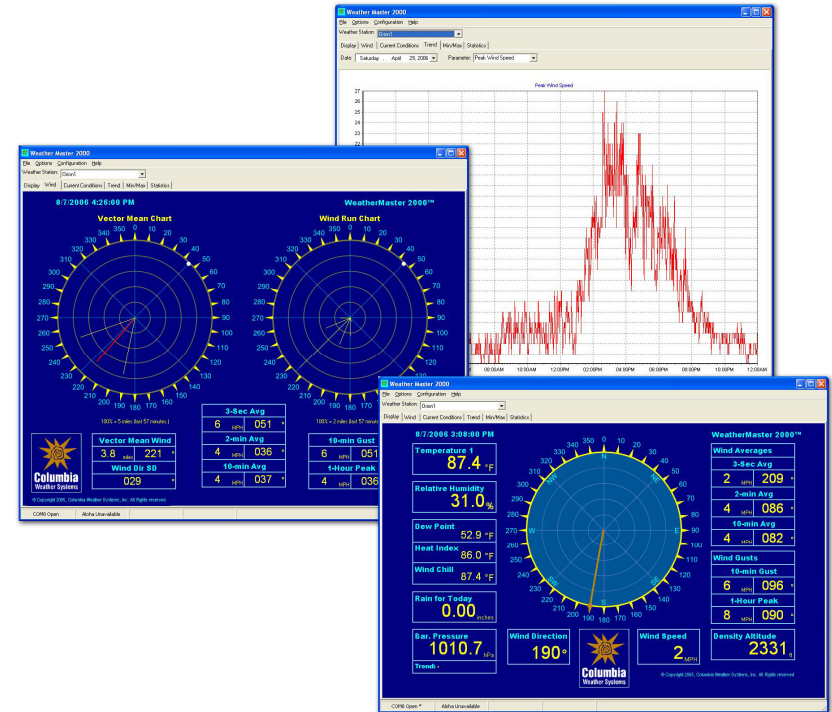

WeatherMaster is a professional grade weather monitoring software. This software package is designed for specialized markets that require robust weather calculations, interoperability with computer models, and data interfaces to other industrial systems. WeatherMaster utilizes Microsoft Access database for easy data access and manipulation.

Weather View 32™ Software (optional)

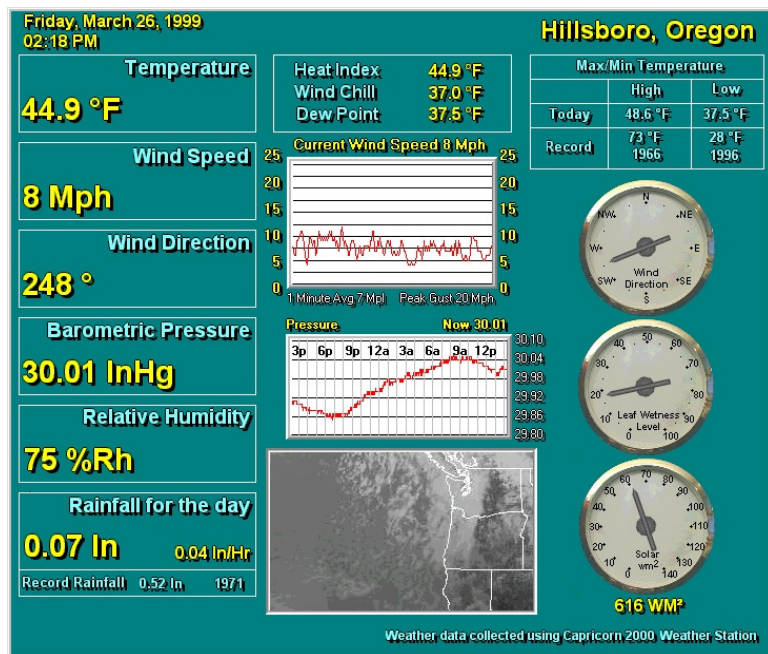

Operating in Windows graphic environment, Weather View 32 helps you monitor, record, and store local weather data for current or future analysis.

Weather View 32 offers:

- User-defined real time monitoring display
- Internet and email interface
- Calculated parameters including wind chill, dew point, heat index and degree days
- Monthly calculations for degree days heating and cooling
- Full-featured graphing and printing capabilities
- Six separate alarms functions
- A Climatological database that covers the U.S. and Canada
- Modem access for remote weather stations

SECTION 6: CALIBRATION

Calibrating the Barometric Pressure Sensor

The barometric pressure sensor is calibrated at the factory to a highly accurate digital pressure gauge ($\pm 0.02\%$ of full range) and traceable to NIST and, therefore, it requires no further calibration.

The barometric pressure sensor in the Pegasus EX is temperature compensated from 32° to 185° F and has an accuracy of ± 0.03 in.Hg.

Altitude Setting

After calibration at the factory, the altitude is set to zero. To get an accurate barometric pressure reading, the local altitude needs to be set in the weather station.

To set the altitude, use the ALT command and enter the altitude in feet. Please refer to Section 4: Operation for more information. The altitude can also be set using weather software or display console. Please refer to the software or display console user manual.

Note: The electronic transducer used to measure air pressure is sensitive to changes in elevation of as little as 10 ft. (3 m).

Optional Calibration Procedure

Even though the barometric pressure sensor is calibrated at the factory, the sensor can be re-calibrated on-site. This might be required if the original barometric pressure offset has been erased from memory, or if weather station needs to match a local source.

To re-calibrate the barometric pressure on-site:

Using a terminal program, set the barometric pressure offset to zero by entering: 0 BAR-OFFSET

Wait approximately 5 seconds, then take a pressure reading using SAMPLE, POLL or P1

Record the barometric pressure from a local reliable source at the same elevation as the Pegasus.

Calculate the barometric pressure offset as follows:

Barometric Pressure Offset = Source Reading – Pegasus EX Reading.

Enter the barometric pressure offset in 1/100 of in.Hg using the BAR-OFFSET command.

Weather Display Console (Optional)



The Weather Display uses “intelligent” touch-screen technology. With its programmable microprocessor and abundant memory, the Weather Display can display weather information, perform complex computations, and store relatively large amounts of weather data.

The Weather Display is also available in a 19” rack-mount chassis.

S,05/01/99,09:46,40WD,000WS,00.00R,023RH,29.10P1,+070.72T1,+255.00T2,04.80LW,5.00X1,0
.10X2,4928

S,05/01/99,09:46,40WD,000WS,00.00R,023RH,29.10P1,+070.72T1,+255.00T2,04.80LW,5.00X1,0
.10X2,4928okok

An <Esc> followed by <Enter> terminates this command. The output will stop after one more Sample record is issued. For example, if CONT is set to repeat the Sample record every 15 seconds (15 CONT) and an <ESC><ENTER> was entered, one more Sample record will be issued before the double ok is displayed indicating that the command is terminated.

W00124

S,02/11/98,17:44,24WD,001WS,00.08R,085RH,29.82P1,+048.56T1,+070.85T2,+067.24T3,+065.08T4,01.74LW,0.00X1,0.00X2,6014

W00224

W00224

W00124

W00124

W00124

W00120okok

An <Esc> followed by <enter> terminates this command.

XSET: This command defines the frequency the Sample record is displayed in the XFER output. The default frequency of the Sample record in the XFER output is 60 seconds. This frequency can be changed using the XSET command. For example, 15 XSET will cause the Sample record to be issued every 15 seconds. XSET will change the frequency of the XFER output on both serial ports.

CONT: This command will continuously output the Sample record at a specified interval. For example, 5 CONT will output a Sample record every 5 seconds. The time interval is limited to a range of 1 to 16 seconds.

S,05/01/99,09:44,40WD,000WS,00.00R,022RH,29.10P1,+070.70T1,+255.00T2,04.80LW,5.00X1,0.10X2,4923

S,05/01/99,09:44,40WD,000WS,00.00R,023RH,29.09P1,+070.70T1,+255.00T2,04.80LW,5.00X1,0.10X2,4932

S,05/01/99,09:44,40WD,000WS,00.00R,023RH,29.09P1,+070.70T1,+255.00T2,04.80LW,5.00X1,0.10X2,4932

S,05/01/99,09:44,40WD,000WS,00.00R,023RH,29.10P1,+070.70T1,+255.00T2,04.80LW,5.00X1,0.10X2,4924

S,05/01/99,09:45,40WD,000WS,00.00R,023RH,29.10P1,+070.70T1,+255.00T2,04.80LW,5.00X1,0.10X2,4925

S,05/01/99,09:45,40WD,000WS,00.00R,023RH,29.10P1,+070.70T1,+255.00T2,04.80LW,5.00X1,0.10X2,4925

S,05/01/99,09:45,40WD,000WS,00.00R,023RH,29.10P1,+070.70T1,+255.00T2,04.80LW,5.00X1,0.10X2,4925

S,05/01/99,09:45,40WD,000WS,00.00R,023RH,29.10P1,+070.70T1,+255.00T2,04.80LW,5.00X1,0.10X2,4925

SECTION 3: INSTALLATION

Please read the complete installation instructions before proceeding.

1. Before installing the tripod legs, install the radiation shield by slipping it over the sensor mast extension. Do not tighten wing nuts at this time.
2. Slip the guy wire collar over the sensor mast
3. Install the wind sensor assembly on the top of the mast. Align the North mark on the wind sensor alignment adapter to the North mark on the mast and tighten the two set screws using a 5/32" allen wrench. By removing the socket head screw in the alignment adapter, the sensor may be removed and replaced without realignment.

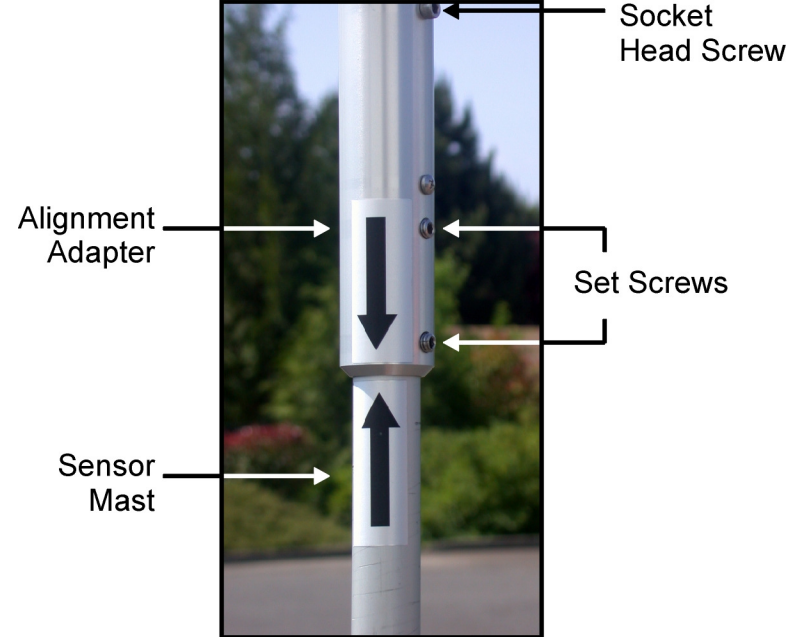

- Remove and retain the shoulder screw from the vane hub. Check to see that the vane assembly rotates freely.

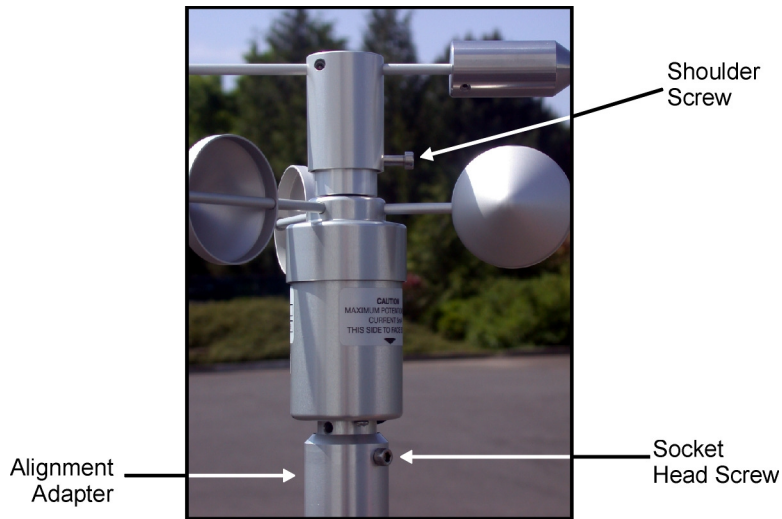

- Connect the cable to the sensor. Route the cable to the Control Module.
- Connect the three legs of the tripod using the pins as shown below.

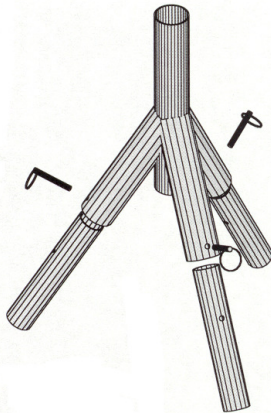

Setting barometric pressure altitude and offset

n ALT: This command sets the altitude of the weather station, where n is the altitude in feet.

Example: 225 ALT sets the altitude to 225 feet above sea level.

n BAR-OFFSET: This command is used to enter an offset to the barometric pressure reading, where n is the offset in 1/100 of in.Hg.

Example: 34 BAR-OFFSET adds 0.34 in.Hg to the barometric pressure reading and -34 BAR-OFFSET subtract 0.34 in.Hg from the reading.

Please refer to Barometric Pressure Calibration for more information.

Display current settings

PARAMETERS: This command displays the current weather station settings and the number of records in the datalog.

Example:

Date & Time	02/11/1998,17:31
Measurement interval	1 minute
Hi/Lo interval	1 hour
Records in memory	262
Pressure offset	38
Altitude	225
Temperature 1 offset	255
Temperature 2 offset	-25
Temperature 3 offset	55
Temperature 4 offset	155 ok

Continuous display of direction

NORTH: This command continuously displays the wind direction. This command is used for locating the north direction on the wind sensor. An <Esc> followed by <Enter> terminates this command.

Continuous display of wind information

1 XFER: This command continuously displays a Sample record every one minute and wind speed and direction every one second. The wind speed and direction record starts with the letter W followed by three digits for wind speed in MPH followed by two digits for wind direction.

Example:

Resetting Hi/Lo

RESET-HI/LO: This command will erase the high/low values from memory for the current high/low interval.

Resetting the datalog

RESET-DATA: This command will erase the datalog and will insert one current Sample record.

Displaying current Hi/Lo

HIGH: This command will display the current high record. The High record starts with the letter H followed by the date and time the record was requested followed by the high values and the time for wind speed, relative humidity, pressure, temperatures, leaf wetness and two undefined sensors (X1 and X2). The high value of wind speed is the wind gust.

Example:

```
H,02/11/98,14:00,013,13:25WS,081,13:40RH,29.86,13:27P1,+053.23,14:00T1,+072.27,13:52T2,+069.59,13:31T3,+065.88,14:00T4,01.70,13:57LW,0.00,14:00X1,0.00,14:00X2,8351
```

LOW: This command will display the current low record. The Low record starts with the letter L followed by the date and time the record was requested followed by the low values and the time for wind speed, relative humidity, pressure, temperatures, leaf wetness and two undefined sensors (X1 and X2). The low value of wind speed is the high 4 second sustained wind average.

Setting temperature offsets

Temperature offsets are used to calibrate the temperature probes.

n TCAL#: This command is used to enter an offset for a temperature probe. Where n is the offset in 1/100 of a degree F and # is the temperature probe number.

Example: 231 TCAL2 adds 2.31 degree F to the temperature reading from temperature probe two and -231 TCAL2 subtracts 2.31 degrees F from the reading.

Please refer to the Temperature Calibration section for more information.

5. Extend the mast to full length and secure with the attached pin. Be sure that the North marks on the sensor mast and the tripod body are aligned.

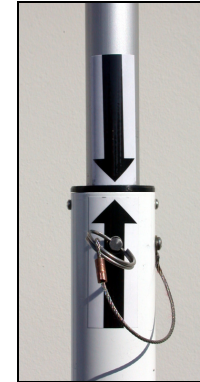

6. Tighten the guy wire turnbuckles so that the sensor mast is aligned vertically.

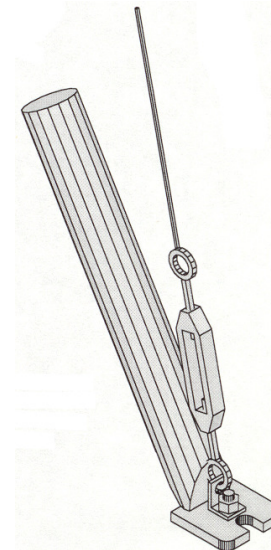

7. Position the radiation shield toward the lower part of the sensor mast extension and tighten using the two wing nuts.

8. Using the attached compass, orient the entire tripod system to magnetic North as shown below. The tripod leg marked North should be pointing to North and the wind sensor should be aligned so that the vane is pointing to North (when it is in the locked position).

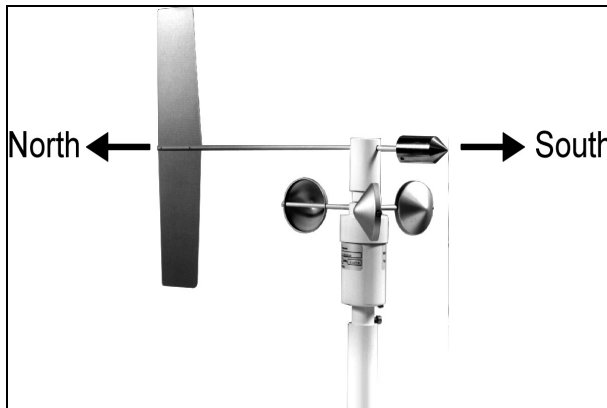
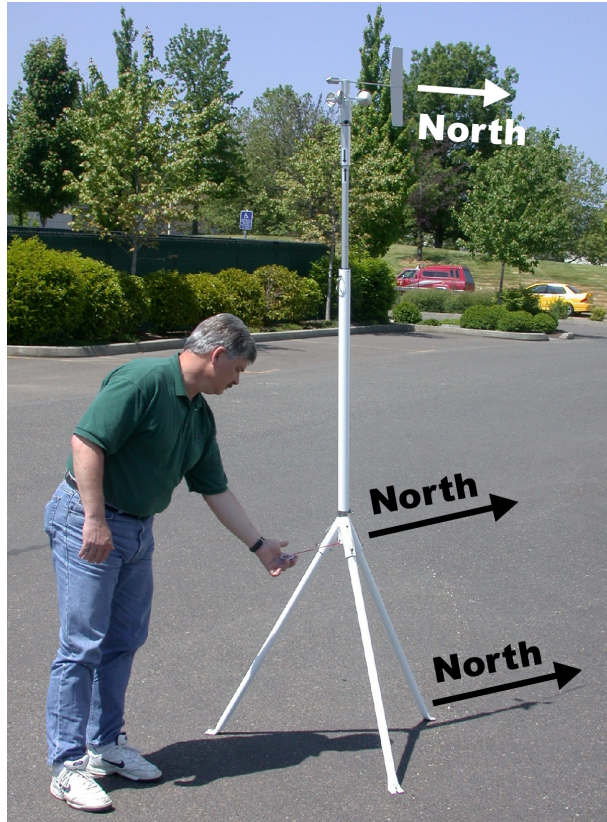

Example: 12 HI/LO-INT will cause the weather station to save High/Low records (total of four records) every 12 hours.

Displaying the datalog

ALL: This command will display the complete datalog (511 maximum records)

Example: In this example the Sample interval is set at one minute and the High/Low interval is set at one hour and the datalog has 13 record (9 Sample records and 4 High/Low records).

13 records

```
S,02/11/98,13:56,32WD,007WS,00.07R,074RH,29.85P1,+052.31T1,+071.62T2,+069.17T3,+065.57T4,01.88LW,0.00X1,0.00X2,6015
```

```
S,02/11/98,13:57,32WD,005WS,00.07R,074RH,29.86P1,+052.74T1,+071.83T2,+069.26T3,+065.69T4,01.70LW,0.00X1,0.00X2,6019
```

```
S,02/11/98,13:58,32WD,006WS,00.07R,072RH,29.85P1,+052.76T1,+071.64T2,+069.35T3,+065.75T4,01.74LW,0.00X1,0.00X2,6020
```

```
S,02/11/98,13:59,32WD,006WS,00.07R,071RH,29.85P1,+052.94T1,+071.86T2,+069.36T3,+065.81T4,01.74LW,0.00X1,0.00X2,6022
```

```
H,02/11/98,14:00,013,13:25WS,081,13:40RH,29.86,13:27P1,+053.23,14:00T1,+072.27,13:52T2,+069.59,13:31T3,+065.88,14:00T4,01.70,13:57LW,0.00,14:00X1,0.00,14:00X2,8351
```

```
L,02/11/98,14:00,013,13:25WS,067,13:25RH,29.84,13:25P1,+050.17,13:39T1,+071.29,13:26T2,+068.33,13:42T3,+065.34,13:25T4,04.41,13:27LW,0.00,00:00X1,0.00,00:00X2,8349
```

```
S,02/11/98,14:00,28WD,000WS,00.07R,071RH,29.85P1,+053.23T1,+072.02T2,+069.26T3,+065.88T4,01.76LW,0.00X1,0.00X2,5998
```

```
S,02/11/98,14:01,28WD,003WS,00.07R,071RH,29.85P1,+053.67T1,+072.52T2,+068.91T3,+065.88T4,01.78LW,0.00X1,0.00X2,6018
```

```
S,02/11/98,14:02,32WD,006WS,00.07R,069RH,29.85P1,+053.70T1,+072.86T2,+068.89T3,+065.86T4,01.84LW,0.00X1,0.00X2,6027
```

```
S,02/11/98,14:03,32WD,003WS,00.07R,068RH,29.85P1,+053.73T1,+073.13T2,+069.21T3,+065.86T4,01.88LW,0.00X1,0.00X2,6009
```

```
S,02/11/98,14:04,28WD,005WS,00.07R,067RH,29.85P1,+053.41T1,+072.48T2,+069.36T3,+065.86T4,01.94LW,0.00X1,0.00X2,6021ok
```

Note that the Sample records start with the letter S and the High/Low records start with the letter H and L respectively.

NOW: This command will display the last record in the datalog

n GET: This command will display a user defined number of records in the datalog, where n is the number of records.

Example: 10 GET will display the last ten records in the datalog.

P1: will display the barometric pressure in inches-Hg

T1: will display the temperature for the first temperature probe in degrees F

T2: will display the temperature for the second temperature probe in degrees F

T3: will display the temperature for the third temperature probe in degrees F

T4: will display the temperature for the fourth temperature probe in degrees F

LW: will display leaf wetness in volts. The range may vary per sensor. Typically, 0.5 volts indicates saturated condition and 4.5 volts indicates dry conditions.

X1 and X2 channels are not used with the Pegasus EX FlyAway Kit

Datalog

The Pegasus EX weather station has a built in circular datalogger. The datalog holds records of sensor readings (Samples) and High/Low information. Both types of records (Samples and High/Low) are recorded at user defined intervals.

The datalog can hold up to 511 records. A Sample occupies one record and High/Low information occupies four records.

Setting datalog intervals

The interval for the Sample records in the datalog is user selectable. The interval duration is restricted to the following: 1, 2, 3, 4, 5, 6, 10, 15, 20, 30, and 60 minutes.

n MEAS-INT: This command sets the Sample interval in the datalog. n is the interval duration in minutes.

Example: 15 MEAS-INT will cause the weather station to save a Sample record every 15 minutes.

Setting Hi/Lo intervals

The interval for the High/Low records in the datalog is user selectable. The interval duration is restricted to the following: 1, 2, 3, 4, 6, 8, 12 and 24 hours.

n HI/LO-INT: This command sets the High/Low interval in the datalog. n is the interval duration in hours.

9. Secure the tripod using the spring-loaded chain attached to the corkscrew drilling stake (for soil) or the pavement spike (for hard surfaces). Pavement spikes can be purchased from local hardware stores.
10. Attach the Control Module to the tripod using the buckle strap.
11. Connect the sensor cables to the Control Module.
12. Place the battery in its case at the base of the tripod. **Connect the power cable to the battery terminals first and then to the Control Module external connector.**

The system is now operational and is ready to transmit weather data.

The SAMPLE command

SAMPLE: This command is used to display the current sensor readings in a one line record format (the same format as the datalog). The record starts with the letter S followed by the date and time of the sample, followed by the sensor values and ends with a check sum value. All of these fields are comma delimited.

Example:

```
S,02/11/98,11:09,36WD,003WS,00.06R,072RH,29.88P1,+050.59T1,+070.77T2,+068.23T3,+064.6
0T4,04.43LW,0.00X1,0.00X2,6007ok
```

Where, WD is wind direction, WS is wind speed in MPH, R is rain fall in inches, RH is relative humidity percentage, P1 is barometric pressure in Inches-Hg, T1 through T4 are the four temperature sensors in degrees F, LW is leaf wetness in volts, X1 is typically solar radiation (5.00 volts equals 2000 Weather Master 2000-2) and X2 is used for additional sensors (X1 and X2 channels are not available with the Pegasus EX FlyAway Kit).

Temperature channels that are not defined or connected will have a +255.00 reading.

Wind direction is displayed in a 64 degree compass. For example:

		<u>Degrees</u>
0	N	0
4	NNE	22.5
8	NE	45
12	ENE	67.5
16	E	90
20	ESE	112.5
24	SE	135
28	SSE	157.5
32	S	180
36	SSW	202.5
40	SW	225
44	WSW	247.5
48	W	270
52	WNW	292.5
56	NW	315
60	NNW	337.5

The Short commands

WD: will display wind direction in a 64 compass points

WS: will display wind speed in MPH

R1: will display the rain fall for the day in inches

RH: will display relative humidity percentage

Setting date and time

SET-DATE: This command is used to set the internal calendar to the appropriate date. It uses space delimiters between the month field, the day field, the year field, and the command field.

Example: 12 25 96 SET-DATE sets the date to 12/25/1996 and 1 5 01 SET-DATE sets the date to 1/5/2001

SET-TIME: This command is used to set the internal clock to the appropriate military time (24 hours clock). It uses space delimiters between the hours field, minutes fields and the command field.

Example: 13 46 SET-TIME sets the time to 1:46 PM

Displaying date and time

DATE-TIME: This command is used to display the system date and time. When used the weather station will return the date followed by the time, comma delimited.

Example: 02/11/1998,13:20ok

Displaying current sensor readings

There are three ways to display current sensor readings:

The POLL command

POLL: This command is used to display the current sensor readings in a report format. When a POLL command is issued, the weather station will interrogate all the sensors and will display the information

Example:

11:00		Time
02/11/1998		Date
50.14	Degrees F	Temperature 1
70.89	Degrees F	Temperature 2
68.33	Degrees F	Temperature 3
64.46	Degrees F	Temperature 4
29.88	Inches Hg	Barometric Pressure
006	MPH	Wind Speed
SE		Wind Direction
073	Percent	Relative Humidity
00.06	Inches	Rain (Today)
04.43	Volts	Leaf Wetness
01.30	Volt	X1
04.58	Volts	X2
ok		

Section 4: Display Console and Software Installation

The Pegasus EX FlyAway Kit offers several options to view and collect the weather data. All of these options use a wireless link to communicate with the control module.

Weather Display Console

Please refer to the Weather Display user manual for installation and operation instructions.

WeatherMaster™ Software

Please refer to the WeatherMaster user manual for installation and operation instructions.

Weather View 32™ Software

Please refer to the Weather View 32 user manual for installation and operation instructions.

Section 5: Operation

The Pegasus EX communicates with a computer or Weather Display console via wireless interface. The Control Module has two ports available on the back panel (RJ-11 jacks).

RS-232 Modem serial port

This is the main serial port in the system. It is usually connected to the radio transceiver for communication with a computer or a Weather Display.

RS-232 Aux serial port

This is a secondary serial port. It is usually used for direct communication with a computer or a Palm device.

Communication

Normally the weather software or the Weather Display is used for monitoring. Configuration is done through the menu selection of the software or the display console.

The commands described in this section are used when the user wishes to communicate directly with the system using a "terminal" software program such as Hyper Terminal (available with Windows operating systems).

The protocol for both serial ports is the following:

Bits per Second (baud rate): 9600

Data bits: 8

Parity: None

Stop bits: 1

Flow control: None

All commands must be entered using upper case letters and followed by a carriage return.

The weather station will return "ok" after the results of each command. If the command is incorrect, the weather station will return "?".